

1 2 3 4 5 6 7 8 9 10

ITEM 項目	PARTS NAME 零件名稱	Q'TY 數量	MATERIAL 材質	FINISH/REMARK 處理/備註
1	TOP COVER	1	A.B.S	BLACK
2	BOTTOM COVER	1	A.B.S	BLACK
3	HOUSING	1	NYLON	BLACK
4	SHELL	1	STAINLESS	50u" NICKEL PLATING
5	TOP SHELL	1	STAINLESS	50u" NICKEL PLATING
	BOTTOM SHELL	1	STAINLESS	50u" NICKEL PLATING
6	CONTACT	24	Phosphor Bronze	Gold flash selective
7	BUTTON	2	A.B.S	BLACK

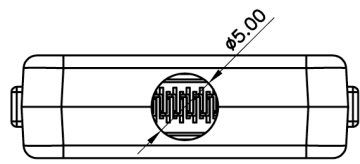
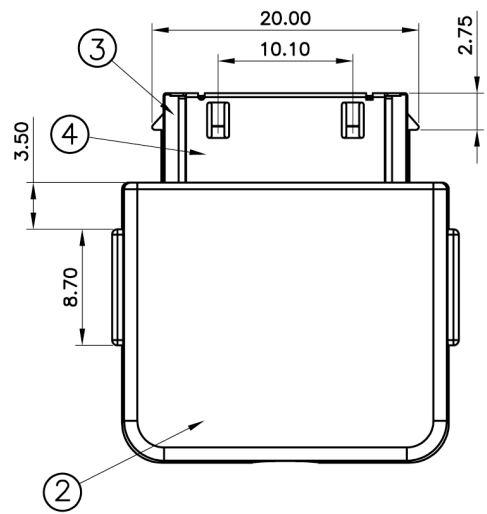
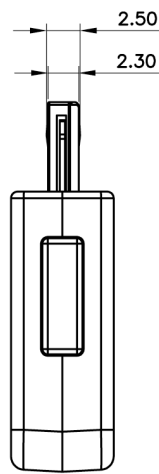
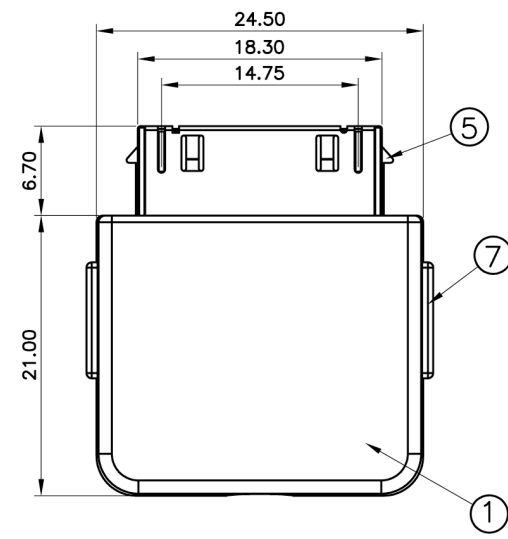
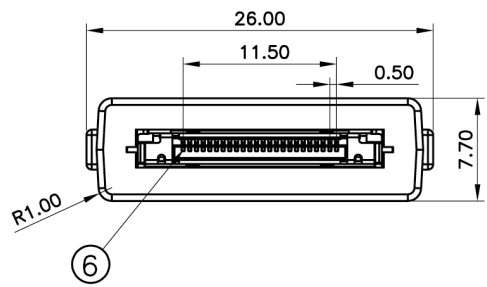

SPECIFICATION
MATERIAL
 See drawing
STANDARD DATA
 Rating current: 0.5A
 Applicable wire: AWG#26 Max.
 Operating temperature: -30°C ~ +60°C
 Storage temperature: -40°C ~ +85°C
ELECTRICAL
 Insulator resistance: 1000M ohms Min. @ 250 VDC
 Withstanding voltage: 100 VAC / minute
 Contact resistance: 50 m ohms Max.
MECHANICAL
 Mating force: 30N(3.06kgf) Max.
 Unmating force (Without lock): 4.2N(0.43kgf) Min.
 Durability: 10000 cycles Min.
 Contact retention force: 4.2N(0.43kgf) Min
PART NO.

SERIES A 1 3 - 694 - 24 01
 MODEL NO. TYPE NO.
 A=Plug in 01=Type1
 TYPE CONTACT NUMBER
 1=0.5mm pitch 24=24position
 CONTACT TYPE 1=SMT type

REFERENCE

Kineteka 1-972-375-4506
 Systems www.kineteka.com

A EXXXX-XXX			MARK X 0		REVISIONS		SIGN		DATE		UNLESS OTHERWISE SPECIFIED TOLERANCE		CHECKED		DESIGNED		TITLE	
REV.	ECN NO.	MARK	REVISIONS		SIGN		DATE		UNLESS OTHERWISE SPECIFIED TOLERANCE		CHECKED		DESIGNED		TITLE		UNIT	
版本	設變號碼	記號	設變內容		修改		日期		尺寸公差		審核		設計 HUABO		產品名稱		MM	
									X. ±0.50		承認		12/1/06"		SMT type-24 position			
									.X ±0.30				DRAWN		PART NO.			
									.XX ±0.20				製圖 HUABO		Z-DOCKM-S1		REV.	
									ANG. ±5'00"				12/1/06"		產品料號		版本	
													SCALE		DOC. NO.		A	
													1.5/1		文件編號			
													A4					
													尺寸					