

**DETAIL A**  
**SCALE 1 : 1**

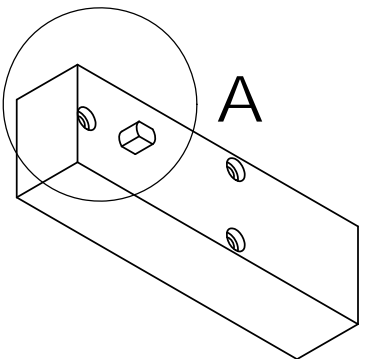

3X mount holes  
for #6 hardware  
(0.14" d, with a  
counterbore  
of 0.265" d, 0.1"  
deep

Wires and connector not  
shown. Connector is Molex KK  
0.1" spacing, 2 pin housing. Wire length  
approx 6 inches.

Wire color identifies  
motor type. Yellow/black - hi speed,  
blue/black - hi torque, red/black - standard

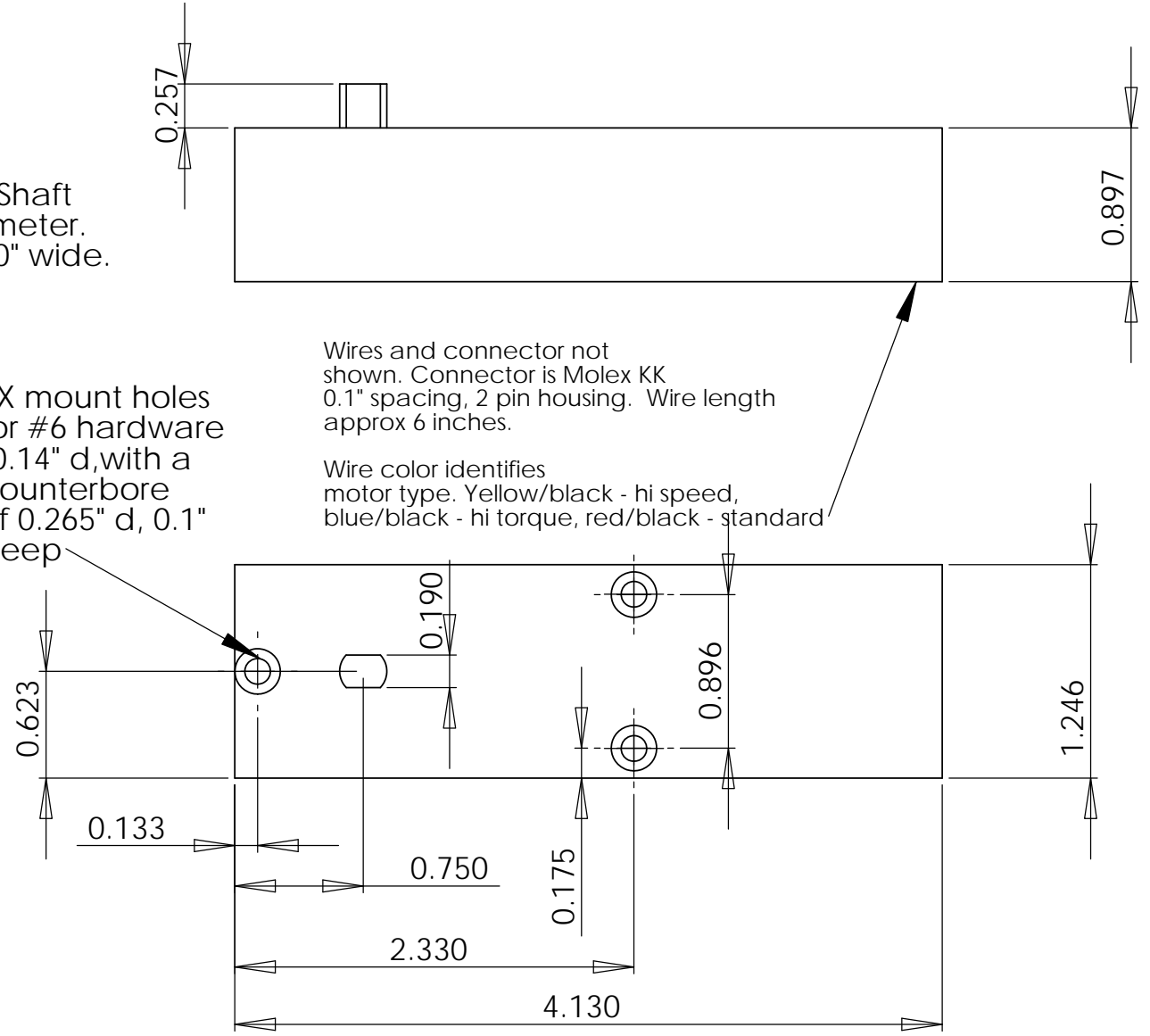

|         |    |      |
|---------|----|------|
| Drawn   | kl | 5/07 |
| Checked | ky | 5/07 |
|         |    |      |
|         |    |      |

TITLE:  
**Active Innovations DC  
Gearbox Motor**

MATERIAL  
ABS case,  
nylon gears  
  
DO NOT SCALE DRAWING

Contents of this drawing  
are property of Active  
Innovations Inc.

|                  |                            |              |
|------------------|----------------------------|--------------|
| SIZE<br><b>A</b> | DWG. NO.<br><b>motorAI</b> | REV          |
| SCALE: 1         | WEIGHT:                    | SHEET 1 OF 1 |