



# MicroMag2

## 2-Axis Magnetic Sensor Module

### General Description

The MicroMag2 is an integrated 2-axis magnetic field sensing module designed to aid in evaluation and prototyping of PNI Corporation's technology. The MicroMag2 combines PNI Corporation's patented Magneto-Inductive (MI) sensors and measurement circuit technology for unparalleled cost effectiveness and performance. The MI sensors change inductance by 100% over its field measurement range. This variable inductance property is used in a cost and space efficient ASIC (PNI 11096) which incorporates a patented temperature and noise stabilized oscillator/counter circuit with an SPI interface. The microprocessor compatible SPI interface allows easy access to the MicroMag2's measurement parameters and resulting field measurement data.

Advantages include 3V operation for compatibility with new systems, low power consumption, small surface mount packaging, large signal noise immunity under all conditions, and a large dynamic range. Resolution and field measurement range are software configurable for a variety of applications. The measurement is very stable over temperature and inherently free from offset drift.

These advantages make PNI Corporation's MicroMag2 the choice for prototyping, education and low volume applications. A reference design is also available for use in high volume applications.

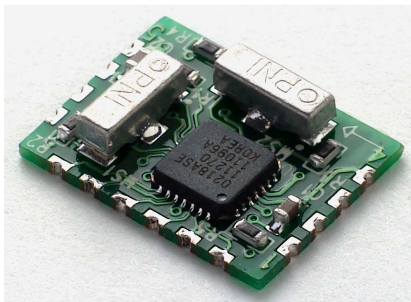

### Features

- Low power: draws < 500  $\mu$ A at 3 VDC
- Small size: 14 x 11 x 2.8 mm
- Large field measurement range:  $\pm 1100 \mu$ T ( $\pm 11$  Gauss)
- High resolution field measurement: 0.015  $\mu$ T (0.00015 Gauss)
- Fast sample rate: up to 2000 samples/second
- Operation: 3.0 VDC
- Fully digital interface: SPI protocol at 3 V
- Surface mount package: 14 pads
- Optional CarrierBoard available for easy prototyping and evaluation

### Applications

- Handheld battery-powered devices with built-in compass feature
- High-performance magnetic field sensing
- High-performance solid state navigation equipment for automotive, marine, and aeronautic applications
- Direction-finding features for any device where bearing or attitude indicators have value

### Ordering Information

Name	Part Number	Package
MicroMag2	11594	Each
MicroMag2 mounted on CarrierBoard	11709	Each



## Absolute Maximum Ratings

Symbol	Parameter	Maximum
V <sub>DD</sub>	DC Supply Voltage	5.25 VDC
V <sub>IN</sub>	Input Pin Voltage	V <sub>DD</sub> + 0.3 VDC
I <sub>IN</sub>	Input Pin Current	10.0 mA at 25 °C
T <sub>STRG</sub>	Storage Temperature	125 °C

Stresses beyond those listed under “Absolute Maximum Ratings” may cause permanent damage to the device. These are stress ratings only. Functional operation of the device at these or any other conditions beyond those indicated in the operational sections of the specifications is not implied. Exposure to absolute maximum rating conditions for extended periods may affect device reliability.

## Module Characteristics

Parameter	Min	Typ	Max	Units
Idle current, measured at ASIC V <sub>CC</sub> (3 VDC, R <sub>b</sub> =43 Ω)		<0.1		mA RMS
Continuous current, measured at ASIC V <sub>CC</sub> (3 VDC, R <sub>b</sub> =43 Ω)		0.4	0.5	mA RMS
Field Measurement Range <sup>(1)</sup> (3 VDC, R <sub>b</sub> =43 Ω)	-1100		1100	μT
Gain <sup>(2)</sup> (P/N 11594) (3 VDC, R <sub>b</sub> =43 Ω)		31.24		Count/μT
Linearity (Error from best fit straight line at ±300 μT)		0.6	1	%
Resolution		1/Gain		μT
Sensor Frequency (3 VDC, R <sub>b</sub> =43 Ω. Within free Earth’s magnetic field.)		175		KHz
Operating Temperature	-20		70	°C
Storage Temperature	-40		125	°C

(1) Field Measurement Range is defined as the monotonic region of the output characteristic curve.

(2) Gain is defined as the change in the number of counts from the ASIC, when the period select is set to 2048, per change in the magnetic field in μT. For situations requiring higher gain and less field measurement range, the gain and resolution can be increased by a factor of 2 by setting the ASIC period select to 4096. When setting higher period selects, be aware that the ASIC counter can overflow if the field is strong enough drive the count beyond a signed 16-bit integer. Period select set to 2048 is the highest setting where it is impossible to overflow the counter. In practical magnetometer applications, a sensor gain calibration is normally performed when the sensor module is in the host system. Gain will change in response to a 5 VDC supply voltage or with the use of alternate bias resistor values. PNI recommends changing the R<sub>b</sub> value to 75 Ω for 5 VDC operations.

**Typical Operating Characteristics: MicroMag2 (3 VDC;  $R_b = 43 \Omega$ )**

**Temperature Characteristics**

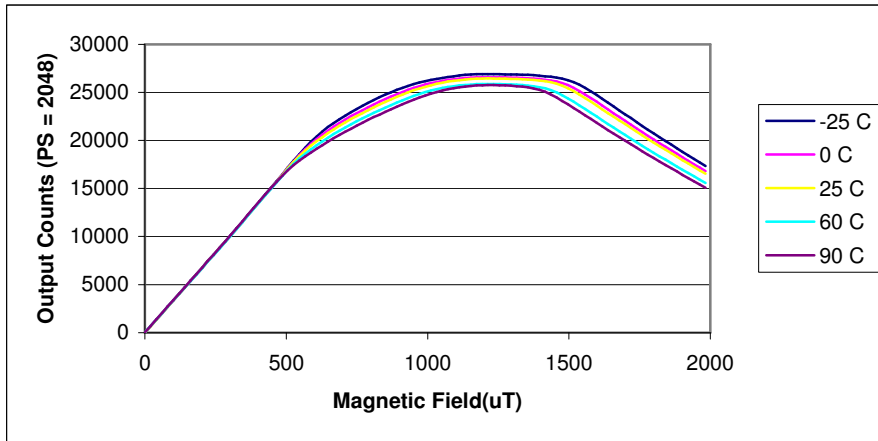

**Linearity vs. Temperature**

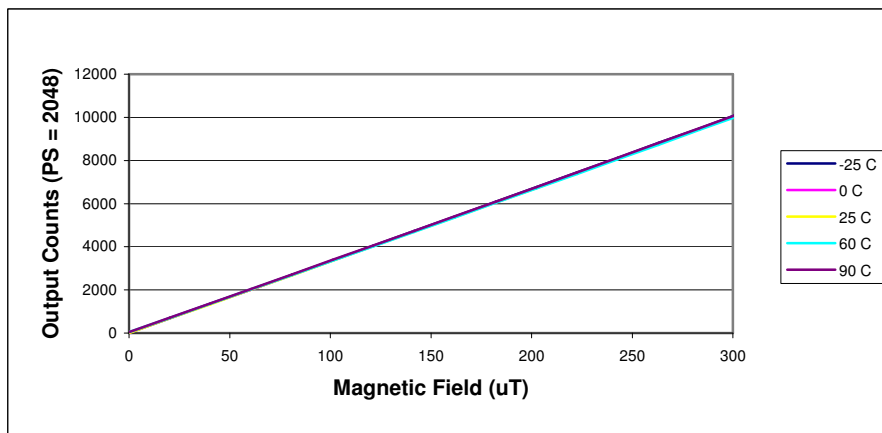

**Linearity vs. Temperature, Normalized to Room Temperature (RMT)**

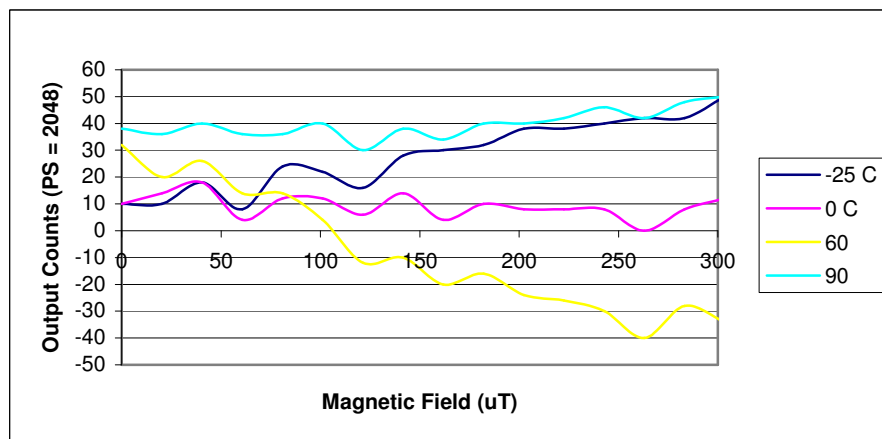

**Output Counts** is defined as the Period Select (PS) setting for the 11096 ASIC. See "PNI-11096, 3-Axis Magneto-Inductive Sensor Driver and Controller with SPI Serial Interface" data sheet for more information.

## Host Processor Interface

All accesses to and from the MicroMag2 are through a hardware handshaking, synchronous serial interface that adheres to the Motorola SPI protocol. The interface consists of six signals; SCLK, MOSI, MISO, SSNOT, RESET and DRDY. See “PNI-11096, 3-Axis Magneto-Inductive Sensor Driver and Controller with SPI Serial Interface” data sheet for detailed information on the interface.

## Pad Descriptions

Pad	Name	Function
1	MOSI	Master Out, Slave In for the module SPI port
2	SSNOT	Active low Chip select for SPI port
3	GND	Ground
4	AVDD	Supply voltage, connected to VDD
5	GND	Ground
6	DVDD	Supply voltage, connected to VDD
7	GND	Ground
8	COMP	Comparator output. Used for diagnostics.
9	RESET	Reset input
10	DRDY	Data Ready
11	DHST	High speed oscillator output (output is ½ clock speed). Used for diagnostics.
12	VSTBY	Input protection clamp diode common, connected to VDD
13	SCLK	Serial Clock input for SPI port, 1Mhz Max (Rext=100K)
14	MISO	Master In, Slave Out for the module SPI port

## ***SPI Port Line Descriptions***

### **MOSI (Master Out Slave In)**

The data sent from the master to the MicroMag2. Data is transferred most significant bit first. The MOSI line will accept data once the SPI is enabled by taking the SSNOT low. Valid data must be presented at least 100 nS before the rising edge of the clock, and remain valid for 100 nS after the edge. New data may be presented to the MOSI pin on the falling edge of SCLK.

### **SSNOT (Slave Select Line)**

Selects the MicroMag2 as the operating slave device. The SSNOT line must be low prior to data transfer and must stay low during the entire transfer. Once the command byte is received by the MicroMag2, and the MicroMag2 begins to execute the command, the SSNOT line can be deselected until the next SPI transfer.

### **SCLK (Serial Clock)**

Used to synchronize both the data in and out through the MISO and MOSI lines. SCLK is generated by a master device. SCLK should be 1 MHz or less. The MicroMag2 is configured to run as a slave device, making it an input. One byte of data is exchanged over eight clock cycles. Data is captured by the master device on the rising edge of SCLK. Data is shifted out and presented to the MicroMag2 on the MOSI pin on the falling edge of SCLK.

### **MISO (Master In Slave Out)**

The data sent from the MicroMag2 to the master. Data is transferred most significant bit first. The MISO line is placed in a high impedance state if the slave is not selected (SSNOT = 1).

## Hardware Handshaking Line Descriptions

### RESET

RESET is usually low. RESET must be toggled from low-high-low.

### DRDY (Data Ready)

DRDY is low after a RESET; after a command has been received and the data is ready, DRDY will be high. It is recommended that the DRDY line always be used to ensure that the data is clocked out of the MicroMag2 only when it is available. If it is determined that the DRDY line cannot be used due to lack of I/O lines to the host processor, then the times listed in the table below can be used to set open-loop wait times. The values listed are the maximum delays from the end of the SCLK command until the rise of the DRDY at each period select setting. The maximum delay occurs when the sensor being sampled is in a zero field

Period Select	Maximum Delay
/32	500 $\mu$ S
/64	1.0 mS
/128	2.0 mS
/256	4.0 mS
/512	7.5 mS
/1024	15 mS
/2048	35.5 mS
/4096	60 mS

## ***Operation***

Basic operation will follow these steps. Refer to the timing diagrams on the following page.

1. SSNOT is brought low.
2. Pulse RESET high (return to low state). You must RESET the MicroMag2 before every measurement.
3. Data is clocked in on the MOSI line. Once eight bits are read in, the MicroMag2 will execute the command.
4. The MicroMag2 will make the measurement. A measurement consists of forward biasing the sensor and making a period count; then reverse biasing the sensor and counting again; and finally, taking the difference between the two bias directions.
5. At the end of the measurement, the DRDY line is set to high indicating that the data is ready. In response to the next 16 SCLK pulses, data is shifted out on the MISO line.

If you need to make another measurement, go to Step 2. You can send another command after the reset. In this case, keep SSNOT low. If you will not be using the MicroMag2, set SSNOT to high to disable the SPI port.

### SPI Port Full Timing Sequence (cpol = 0)

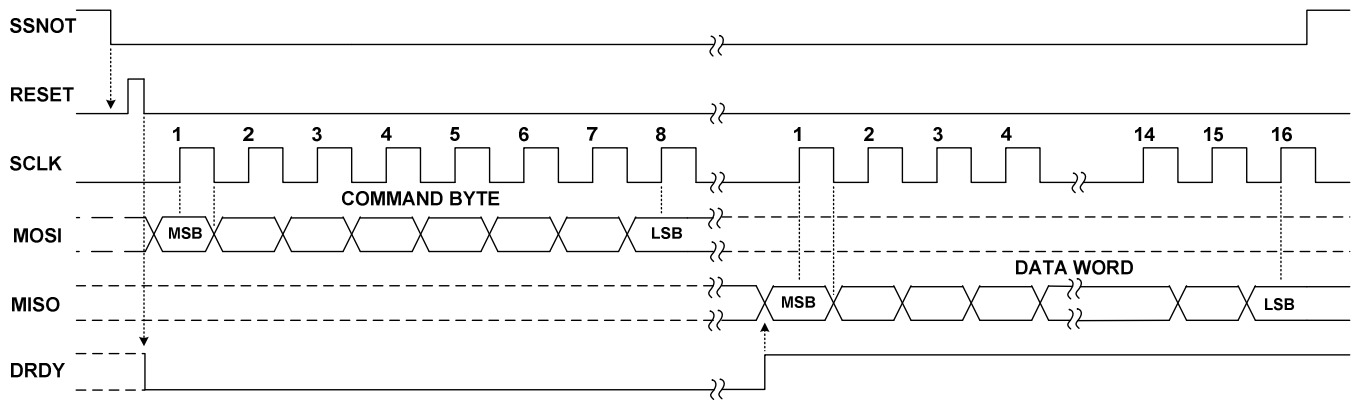

### SPI Port Timing Parameters (cpol = 0)

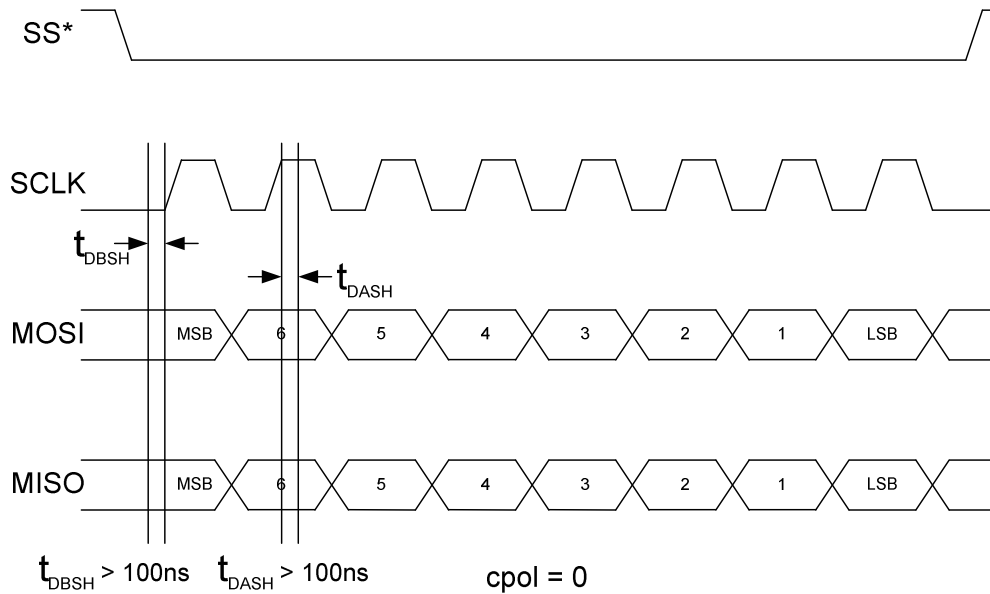



## ***SPI Port Usage Tips***

A SPI port can be implemented using different clock polarity options. The clock polarity used with the MicroMag2 must be normally low, (***cpol = 0***). *SPI Port Timing Parameters* graphically shows the timing sequence (***cpol = 0***). Data is always considered valid while the SCLK is high ( $t_{DASH} = \text{Time, Data After SCLK High}$ ). When SCLK is low, the data is in transition ( $t_{DBSH} = \text{Time, Data Before SCLK High}$ ). When implementing a SPI port, whether it is a dedicated hardware peripheral port, or a software implemented port using general purpose I/O (also known as *Bit-Banging*) the timing parameters given in *SPI Port Timing Parameters* must be met to ensure reliable communications. The clock set-up and hold times,  $t_{DBSH}$  and  $t_{DASH}$  must be greater than 100 nS.

## ***Idle Mode***

The MicroMag2 does not initialize in the idle mode at power-up. The MicroMag2 must be in a data-ready state for the idle mode to occur. After power-up the MicroMag2 can be brought to the data-ready state by following these steps for sending a read command to the MicroMag2.

1. Set SSNOT low.
2. Pulse the RESET line.
3. Send a command to the MicroMag2 to measure one of the sensors.
4. Once the SSNOT pin is set to high again the MicroMag2 will go into the low power idle mode.
5. The DRDY pin will eventually go high signifying that the MicroMag2 is in the data-ready state. The resultant data *does not* have to be read from the MicroMag2.

## ***Magnetic Measurements***

The MicroMag2 magnetic sensor operates as an oscillator circuit composed of the internal sensors, bias resistors, digital gates and a comparator. Only one sensor can be measured at a time. The user sends a command byte to the MicroMag2 through the SPI port specifying the sensor axis to be measured. After dividing by the ratio set by PS2-PS0, the MicroMag2 will return the result of a complete forward - reverse measurement of the sensor in a 16-bit 2's complement format (Range: -32768 to 32767).

## Command Byte

The operation of the MicroMag2 is controlled by the data received into the SPI port. The command byte syntax is as follows:

Position	7	6	5	4	3	2	1	0
Bit	DHST	PS2	PS1	PS0	ODIR	MOT	ASI	ASO
RESET	0	0	0	0	0	0	0	0

### ASO and AS1 (Axis Select)

Determines which axis is being measured.

Function	ASI	AS0
X axis	0	1
Y axis	1	0

### MOT (Magnetic Oscillator Test)

When set, causes the magnetic oscillator selected by AS0 and AS1 in the directions selected by ODIR to run continuously until the MicroMag2 is reset.

### ODIR (Oscillator Direction)

Determines the magnetic oscillator direction if MOT is set to 1. It has no effect on direction when the MOT bit is set to 0. *This is used for debug purposes only, and will not be set in normal operation.*

### DHST (High Speed Oscillator Test)

When high, the internal high speed clock is set to drive the DHST pad at ½ the clock speed. When low, the DHST pad is set to DVDD. *This is used for debug purposes only, and will not be set in normal operation.*

**PS0, PS1, and PS2 (Period Select)**

Selects the division ratio applied to the L/R oscillator output to set the period being measured.

<b>PS2</b>	<b>PS1</b>	<b>PS0</b>	<b>Ratio</b>
0	0	0	/32
0	0	1	/64
0	1	0	/128
0	1	1	/256
1	0	0	/512
1	0	1	/1024
1	1	0	/2048
1	1	1	/4096

### Reference Block Diagram

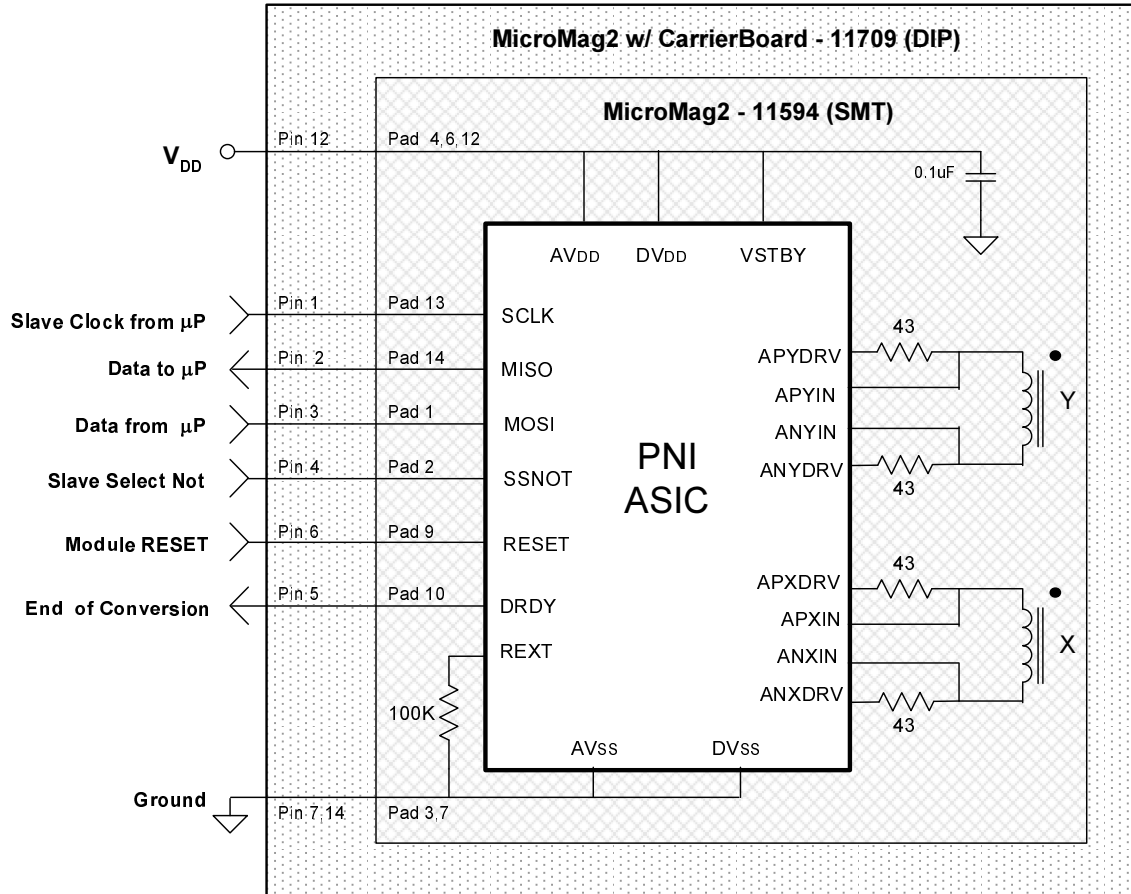

### Package Information

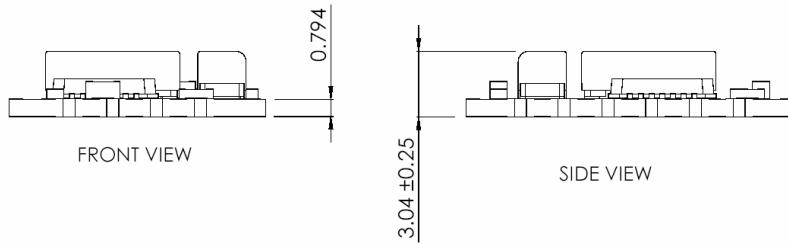

PAD	FUNCTION
1	MOSI
2	SSNOT
3	AVSS
4	AVDD
5	GND
6	DVDD
7	DVSS
8	COMP
9	RESET
10	DRDY
11	DHST
12	VSTBY
13	SCLK
14	MISO

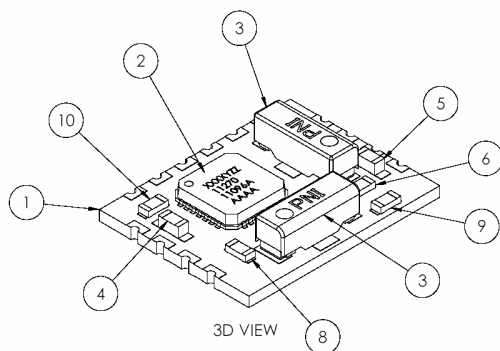
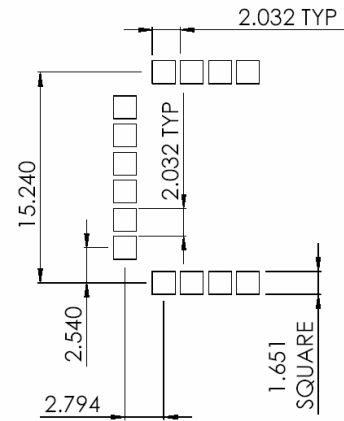
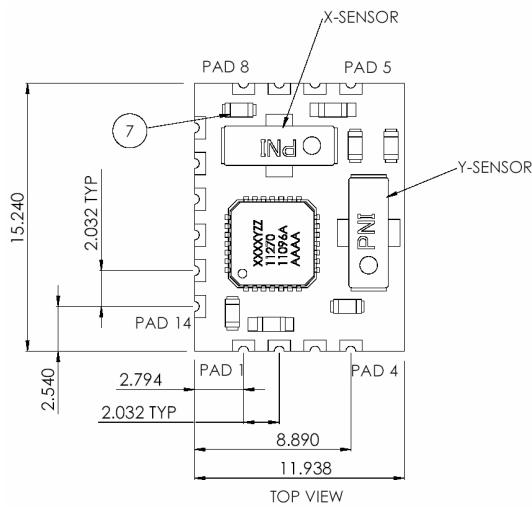

ITEM NO.	QTY.	DESCRIPTION
1	1	PCB MICROMAG MODULE
2	1	ASIC PNI-11096, MLF PACKAGE
3	2	SEN-S65
4	1	CHIP CAPACITOR C1
5	1	CHIP CAPACITOR C2
6	1	CHIP RESISTOR R1
7	1	CHIP RESISTOR R2
8	1	CHIP RESISTOR R3
9	1	CHIP RESISTOR R4
10	1	CHIP RESISTOR R5

NOTES: (UNLESS OTHERWISE STATED)  
 1. PNI PART NO. 11594  
 2. UNITS: ALL UNITS IN STANDARD METRIC, MILLIMETERS.  
 3. TOLERANCES: ± 0.10 MM.

**MicroMag2 Module Mounted on CarrierBoard**

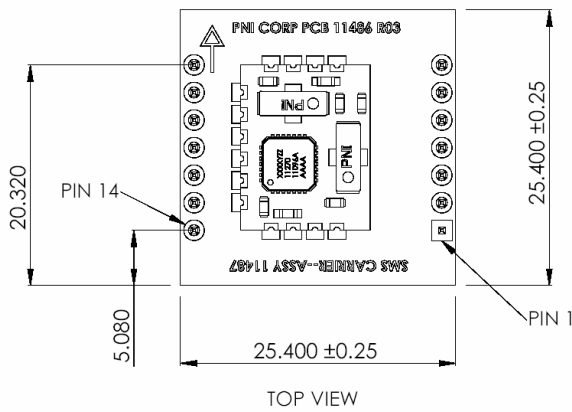
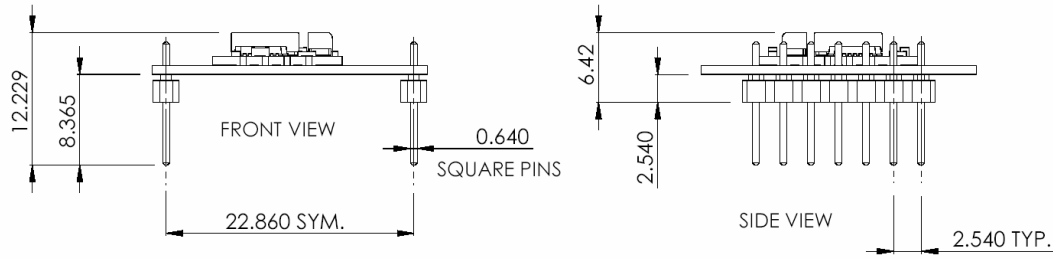

PIN	FUNCTION
1	SCLK
2	MISO
3	MOSI
4	SSNOT
5	DRDY
6	RESET
7	GND
8	N/C
9	N/C
10	N/C
11	N/C
12	VDD
13	N/C
14	GND

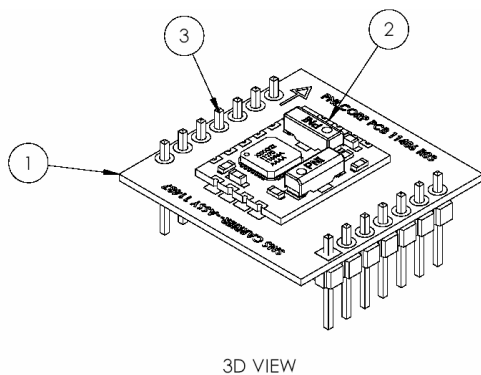

ITEM NO.	QTY.	DESCRIPTION
1	1	PCB MICROMAG CARRIER BOARD
2	1	PCA MICROMAG SENSOR MODULE
3	2	7-PIN HEADER

NOTES (UNLESS OTHERWISE STATED):  
 1. PNI PART NO: 11709  
 2. UNITS: ALL UNITS IN METRIC, MILLIMETERS.  
 3. TOLERANCES: ± 0.10 MM.