

深圳市昱申科技有限公司
CHINA YOUNG SUN LED TECHNOLOGY CO., LTD.

TEL: (86) 755-28079401 28079402 28079403 28079404 28079405
FAX: (86) 755-28079407 E-mail: info@100LED.com Web: www.100LED.com

Model No.: YSL-R341R3D-D2

Applications:

- Decorations
- Bill Insperctor
- Inceticidal Lights
- Medical Appliance

Absolute Maximum Ratings: (Ta=25°C) .

ITEMS	Symbol	Absolute Maximum Rating	Unit
Forward Current	I _F	20	mA
Peak Forward Current	I _{FP}	30	mA
Suggestion Using Current	I _{SU}	16-18	mA
Reverse Voltage (V _R =5V)	I _R	10	uA
Power Dissipation	P _D	105	mW
Operation Temperature	T _{OPR}	-40 ~ 85	°C
Storage Temperature	T _{STG}	-40 ~ 100	°C
Lead Soldering Temperature	T _{SOL}	Max. 260°C for 3 Sec. Max. (3mm from the base of the epoxy bulb)	

Absolute Maximum Ratings: (Ta=25°C)

ITEMS	Symbol	Test condition	Min.	Typ.	Max.	Unit
Forward Voltage	V _F	I _F =20mA	1.8	---	2.2	V
Wavelength (nm) or TC(k)	Δλ	I _F =20mA	620	---	625	nm
*Luminous intensity	I _v	I _F =20mA	150	---	200	mcd
50% Viewing Angle	2θ 1/2	I _F =20mA	40	---	60	deg

Address: 5/F, Building B, Anzhilong Indl., Qinghua East Road., Longhua Town, Shenzhen CHINA. 518109

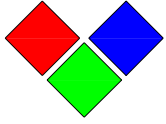

深圳市昱申科技有限公司

CHINA YOUNG SUN LED TECHNOLOGY CO., LTD.

TEL: (86) 755-28079401 28079402 28079403 28079404 28079405

FAX: (86) 755-28079407 E-mail: info@100LED.com Web: www.100LED.com

Light Degradation in mcd: ($I_F=20mA$)

Colors \ Hours	Light Degradation in mcd after Different Hours					
	216 Hrs	360 Hrs	792 Hrs	1104 Hrs	1992 Hrs	2328 Hrs
Red	1.52%	-1.22%	-3.10%	-4.68%	-5.72%	-8.27%
Yellow	-1.71%	-2.97%	-5.93%	-8.13%	-8.90%	-11.10%
Blue	3.13%	-0.33%	-3.84%	-8.23%	-21.32%	-24.92%
Green	-8.02%	-9.78%	-14.25%	-17.37%	-20.79%	-22.30%
Hours	48 Hrs	168 Hrs	336 Hrs	528 Hrs	744 Hrs	1008 Hrs
Cool White	5.28%	3.36%	-1.15%	-3.84%	-8.66%	-11.24%
Pure White	6.83%	4.11%	-0.73%	-4.25%	-9.76%	-12.63%
Warm White	1.51%	-2.19%	-7.59%	-10.53%	-13.58%	-14.98%

Mechanical Dimensions:

- All dimension are in mm, tolerance is $\pm 0.2mm$ unless otherwise noted
- An epoxy meniscus may extend about 1.5mm down the leads.
- Burr around bottom of epoxy may be 0.5mm Maximum

Unit: mm

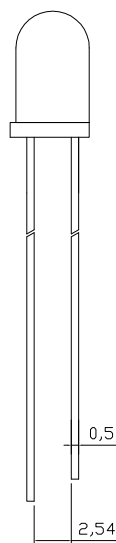
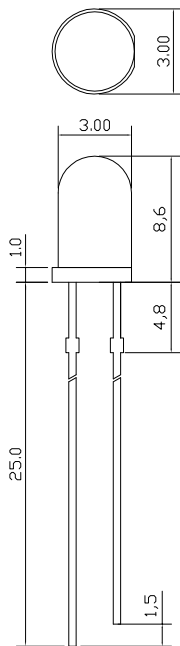

Viewing Angle Drawing

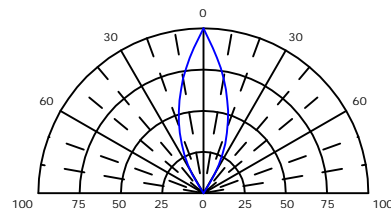

Address: 5/F, Building B, Anzhihong Indl., Qinghua East Road., Longhua Town, Shenzhen CHINA. 518109

www.100LED.com

ONE HUNDRED LED
PERFECT LED

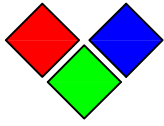

深圳市昱申科技有限公司

CHINA YOUNG SUN LED TECHNOLOGY CO., LTD.

TEL: (86) 755-28079401 28079402 28079403 28079404 28079405

FAX: (86) 755-28079407 E-mail: info@100LED.com Web: www.100LED.com

Packing Information:

1. Anti-static bag

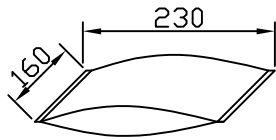

Unit: mm

200 - 500pcs per bag

With 1 little bag of drier inside

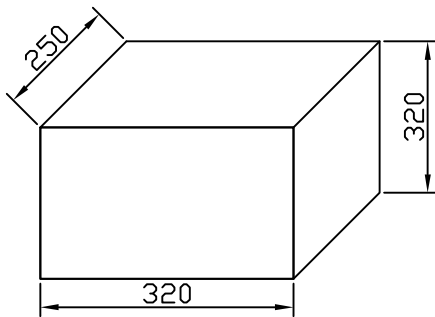

Middle Box

30 - 40 bags per box

15-20K pcs per box

0.45Kg/K

Anti-static Tube Packaging Information:

Unit: mm

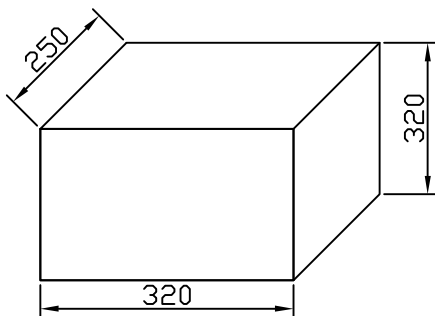
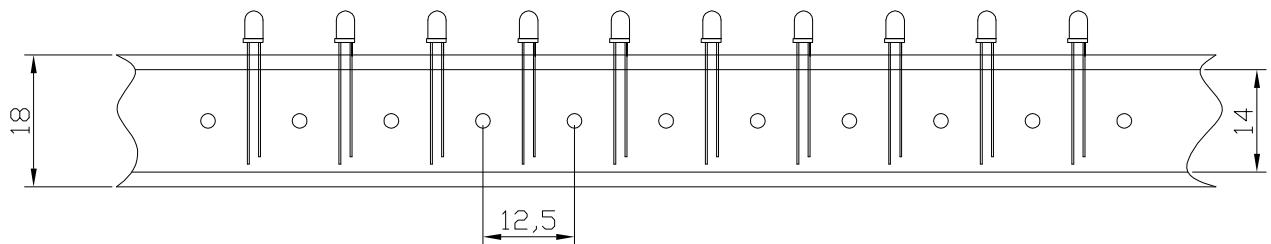

Middle Box

60 pcs per tube.

25 Tubes per layer.

35 Layers per carton

875 Tubes per carton.

52.5K pcs maximum in one carton

20-23Kg per carton

Address: 5/F, Building B, Anzhilong Indl., Qinghua East Road., Longhua Town, Shenzhen CHINA. 518109

www.100LED.com

ONE HUNDRED LED
PERFECT LED

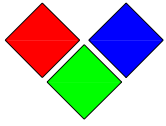

深圳市昱申科技有限公司

CHINA YOUNG SUN LED TECHNOLOGY CO., LTD.

TEL: (86) 755-28079401 28079402 28079403 28079404 28079405

FAX: (86) 755-28079407 E-mail: info@100LED.com Web: www.100LED.com

Code System:

YSL-R341Y3D-D2



1. Company Code, short for Young Sun

2. Code for LED series.

3. Code for LED Type.

R: Round B: Bullet C: Columnar O: Oval
H: Helmet Q: Square V: Concave P: Pagoda
S: Strawhat D: Special

4. Code for LED Lens Type.

5. Code for Lead Frame of LED

6. Code for Lead Frame Code of LED

7. Code for Wavelength Color

8. Code for Lens color

C: Water Clear W: White Diffused D: Color Diffused T: Color Transparent

9. Code for Viewing Angle

A: 1-10 B: 10-20 C: 20-30 D: 30-40 E: 40-60 F: 60-90 G: 90-120 H: >120

10. Luminous Intensity Grade:

1: 1-50mcd	4: 200-300mcd	7: 800-1000mcd	10: 2000-3000mcd	14: 10000-13000mcd
2: 50-100mcd	5: 300-500mcd	8: 1000-1500mcd	11: 3000-5000mcd	15: 13000-15000mcd
3: 100-200mcd	6: 500-800mcd	9: 1500-2000mcd	12: 5000-8000mcd	16: 15000-20000mcd
			13: 8000-10000mcd	17: 20000~mcd

Warranty:

In order to make the LEDs lifespan longer, please set the input Current below 20mA.

Electrical & Optical Characteristics consistency of same items all shipments.

Notes:

Please use LEDs based on our datasheet.

LED is sensitive to statics, be sure your equipments are anti-static when you use our LEDs.

Pay more attention to your heat dissipation system when you use it, the better heat dissipation, the longer LED lifespan.

Address: 5/F, Building B, Anzhihong Indl., Qinghua East Road., Longhua Town, Shenzhen CHINA. 518109

www.100LED.com

ONE HUNDRED LED
PERFECT LED