

SPK S. P. K.
ELECTRONICS CO., LTD.

10F, NO. 510, SEC. 5, CHUNG HSIAO E. RD.,
TAIPEI, TAIWAN, R.O.C.

E-MAIL : spktw@ms34.hinet.net

Web Site: <http://www.spkecl.com>

兆福企業有限公司

台北市忠孝東路五段 510 號 10 樓
(家美國際金融大樓)

TEL: 886-2-2346-2323

FAX: 886-2-2346-3939

APPROVAL SHEET

CUSTOMER'S NAME : _____

MODEL NUMBER : SPK-12M288-5032

12.288M 20PF 30PPM 5*3.2

SPEC RECORD NUMBER : SPK-990212-001

APPROVAL DATE : 2010-02-12

Confirmed Signature:

Authorized Signature:

SPK-5032

GENERAL SPECIFICATIONS
Environmental Specification:
Surface mount crystal

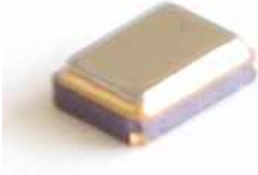

1. GENERAL SPECIFICATIONS

- 1.1 Holder Style : SPK-5032
- 1.2 Frequency : 12.288MHz
- 1.3 Mode Of Oscillation : Fundamental
- 1.4 Frequency tolerance at 25°C : +/- 30 PPM
- 1.5 Frequency Stability at (-20°C ~ +70°C) : +/- 30 PPM
- 1.6 Load Capacitance (CL) : 20pf
- 1.7 Static capacitance (CO) : 6PF max
- 1.8 Ts :
- 1.9 Resonance Resistance (RR) : 50 Ω
- 1.10 Drive Level : 10 uW max
- 1.11 Insulation Resistance : 10M ohm MIN
- 1.12 Aging : +/-3ppm/year
- 1.13 Operating temperature : -20 °C ~ +70 °C
- 1.14 Measurement Condition : the reference temperature shall be at 25°C ± 2°C

3.Dimension

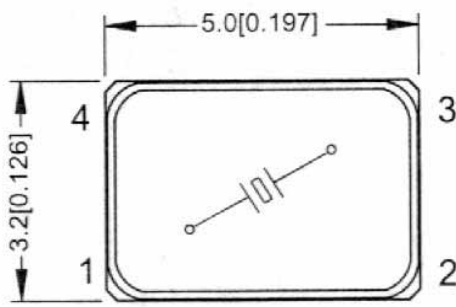

Pad 1 and 3: Crystal
 Pad 2 and 4: Metal lid and ground
 Chamfered pad is pad No. 1

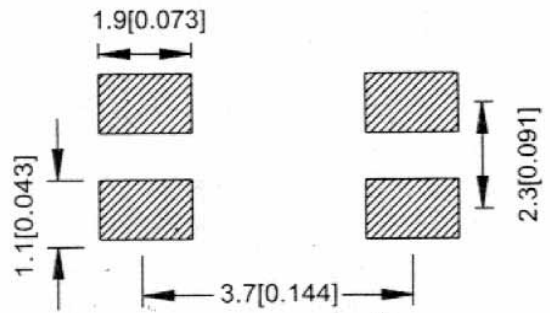
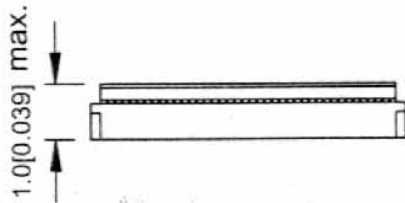
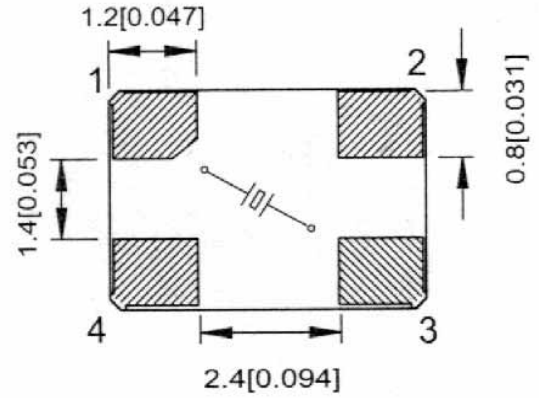

4. Marking: laser marking

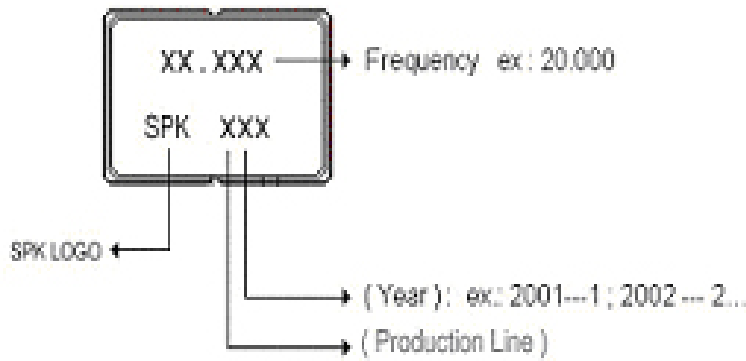

5. Package and Label

5.1 Package dimension: 1 REEL : 1000 PCS

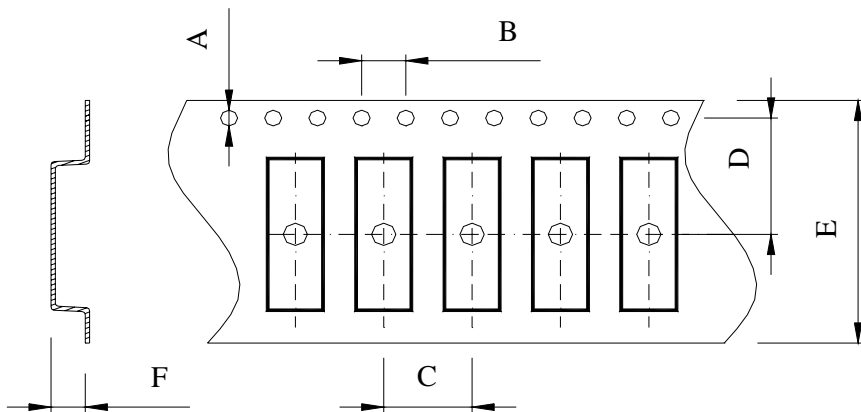

A	B	C	D	E	F
1.50	4.0	8.0	5.5	12.0	1.1

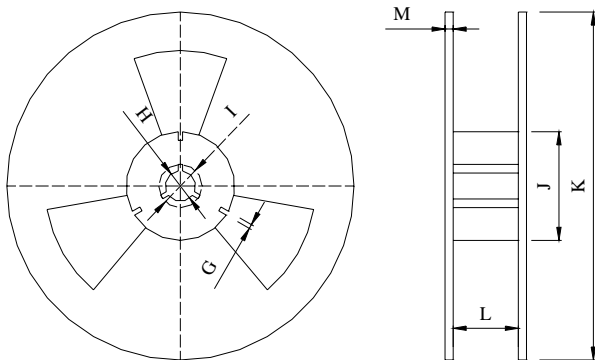

G	H	I	J	K	L	M
2.5	13.0+/-0.2	21.0+/-1	60	180	17.65	1.4

.Carton Dimension (unit : mm)

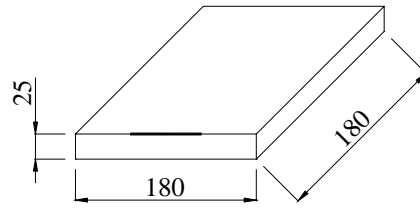
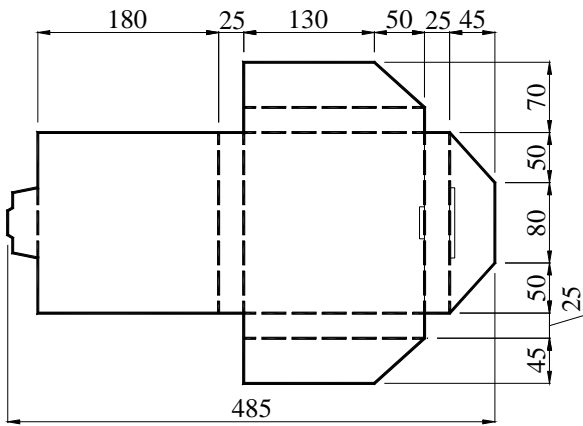

1 reel = 1 Inner box

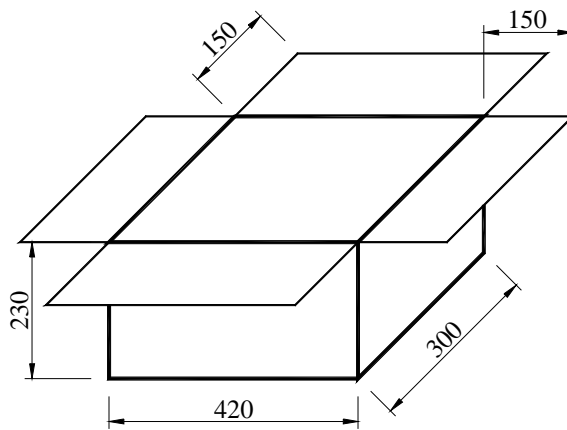
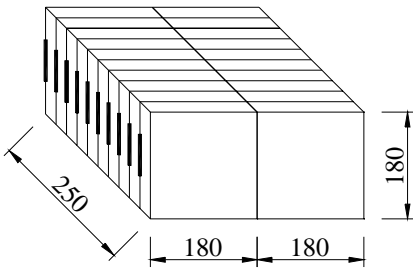

20 Inner boxes = 1 Carton

20kpcs = 1 Carton