

GPS Engine Board

EB-230

EB-230 is an ultra miniature 12 x 12 mm² GPS engine board. It provides superior navigation performance under dynamic conditions in areas with limited sky view like urban canyons. High sensitivity up to **-158dBm** for weak signal operation without compromising accuracy. EB-230 is your best choice for embedded applications.

Key Features :

- Small form factor: 12 x 12 x 3 mm
- Lead-Free – RoHS/WEEE compliant
- High sensitivity -158dBm
- Tracks 32-Channel of satellites
- Fast Position Fix
- Low power consumption

Applications :

- Handheld devices
- Automotive and Marine Navigation
- Automotive Navigator Tracking
- Emergency Locator
- Geographic Surveying
- Personal Positioning
- Sporting and Recreation
- Embedded applications : PDA, DSC, Smart phone, UMPC, PND, MP4

PIN Definition :

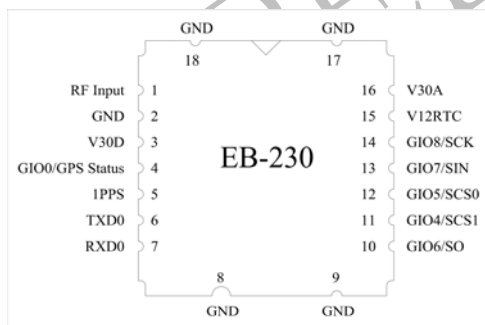

PIN Coordinates

Unit:mm

Pin #	X	Y	Pin #	X	Y
1	0.00	0.00	10	12.50	7.62
2	0.00	1.27	11	12.50	6.35
3	0.00	2.54	12	12.50	5.08
4	0.00	3.81	13	12.50	3.81
5	0.00	5.08	14	12.50	2.54
6	0.00	6.35	15	12.50	1.27
7	0.00	7.62	16	12.50	0.00
8	4.06	10.06	17	9.71	-2.44
9	9.71	10.06	18	2.79	-2.44



TRANSYSTEM INC.

An A+ supplier of RF microwave & GPS products

Ultimate

EB

EB-230 Specifications

Specification	Description
General	L1 frequency, C/A code (SPS) 32 independent tracking channels
Sensitivity	-158dBm /Tracking; -146dBm /Acquisition
Update Rate	Up to 5Hz
Accuracy	Without aid: 3.0m 2D-RMS <3m CEP (50%) without SA (horizontal) DGPS (WAAS, EGNOS, MSAS, RTCM): 2.5m
Acquisition (open sky)	Cold Start: 36sec Warm Start: 33sec Hot Start: 1sec
Reacquisition	< 1sec
Dynamics	Altitude: 18000m (max.) Velocity: 515m/sec (max.) Vibration: 4G (max.)
Supply Voltage	DC 3.0V
Power Consumption	< 30mA @ 3.0V (w/o Active ANT) / Tracking
Backup Battery	DC 1.2V (RTC Vcc)
NMEA Message	NMEA0183 v3.1 baud rate 4800/9600/.../57600, default 9600 Protocol: 3V CMOS/TTL Selectable Output: GGA, GLL, GSA, GSV, RMC, and VTG
Datum	Default WGS-84
Antenna	External Active Antenna Output Voltage: 3.0 VDC
Serial Interface	RS-232, SPI
Operating Temperature	-30°C to 85°C
Storage Temperature	-40°C to 125°C
Operating Humidity	≤ 95%, non condensing
Mounting	SMT Type, 18 Pin
Dimension	12 x 12 x 3(H) mm

*Specifications subject to change without prior notice.

© TRANSYSTEM INC. all rights reserved.



No.1-2 Li-Hsin Rd.I, Science-Based
Industrial Park, Taiwan, R.O.C.
T: +886-3-5780393 / F: +886-3-5784111
gps.sales@transystem.com.tw
www.transystem.com.tw

Table of Contents

1	Introduction	4
1.1	Key Features	4
1.2	Applications	4
1.3	Look & Feel	4
2	Technical Description	5
2.1	Block Diagram	5
2.2	Pin Definition	5
2.3	Specification	6
3	User Interface	7
3.1	Protocol	7
3.1.1	NMEA Protocol	7
3.1.2	MTK NMEA Packet Format	8
3.1.3	MTK NMEA Packet Protocol	8
3.1.4	MTK NMEA Packet List	8
4	Dimension and Package	13
4.1	Mechanical Dimension	13
4.2	Recommend Layout Pattern	13
4.3	Package	13
5	Application Information	14
5.1	GPS Antenna Recommendations	14
5.2	Application Circuit	14
5.3	General GPS Receiver User's Tips	15

1 Introduction

EB-230 is an ultra miniature 12 x12mm² GPS engine board. It provides superior navigation performance under dynamic conditions in areas with limited sky view like urban canyons. High sensitivity up to -158dBm for weak signal operation without compromising accuracy. EB-230 is your best choice for embedded applications.

1.1 Key Features

- Small form factor: 12 x 12 x 3 mm
- Lead-Free – RoHS/WEEE compliant
- High sensitivity -158dBm
- Tracks 32-Channel of satellites
- Fast Position Fix, 36/ 33/ 1s for Cold/ Warm/ Hot start
- Low power consumption

1.2 Applications

- Handheld devices
- Automotive and Marine Navigation
- Automotive Navigator Tracking
- Emergency Locator
- Geographic Surveying
- Personal Positioning
- Sporting and Recreation
- Embedded applications such as: PDA, DSC, Smart phone, UMPC, PND, MP4

1.3 Look & Feel

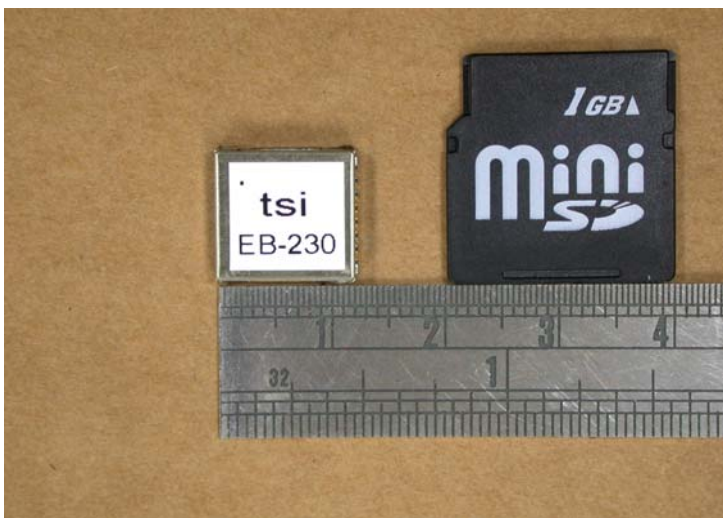

2 Technical Description

2.1 Block Diagram

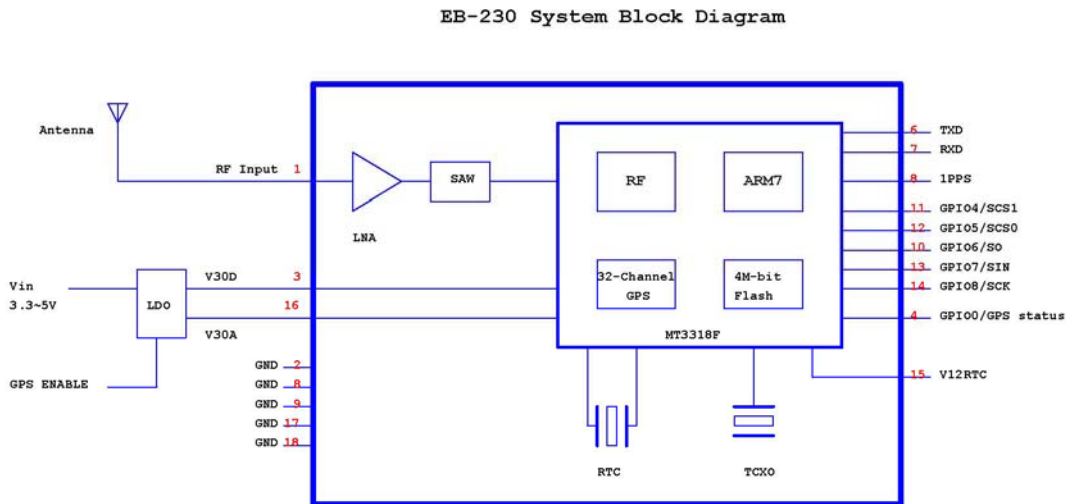

2.2 Pin Definition

Pin#	Signal Name	Type	Description
1	RF Input	I	Antenna port, L1, 1575.42MHz, 50 ohm
2	GND	P	Ground
3	V30D	P	Digital power supply, 3.0V±10%
4	GPS status/ GPIO0	O	GPS status, blink when GPS has position fix General input/ output
5	1PPS	O	1Hz pulse 10% duty cycle when GPS has position fix
6	TXD	O	3V CMOS level, data output from EB-230
7	RXD	I	3V CMOS level, data into EB-230
8	GND	P	Ground
9	GND	P	Ground
10	GPIO6/SO	I/O*	General input/ output, SPI data output
11	GPIO4/SCS1	I/O*	General input/ output, SPI chip select 1
12	GPIO5/SCS0	I/O*	General input/ output, SPI chip select 0
13	GPIO7/SIN	I/O*	General input/ output, SPI data input
14	GPIO8/SCK	I/O*	General input/ output, SPI clock
15	V12RTC	P	RTC power 1.0~1.5Vdc, 500uA max
16	V30A	P	Analog power supply, 3.0V±10%
17	GND	P	Ground
18	GND	P	Ground

P: Power I: Input O: Output I/O*: Input or Output, Open if not used

2.3 Specification

General	
GPS technology	MTK GPS chipset
Frequency	L1, 1575.42 MHz
C/A Code	1.023 MHz chip rate
Channels	32 channels all in view tracking
Sensitivity	Better than -158dBm
Receiver Accuracy	
Position	Without aid: 3.0 m 2D-RMS DGPS (WAAS, EGNOS, MSAS, RTCM): 2.5 m
Velocity	Without aid: 0.1 m/s
Time	100 ns RMS
Datum	
Datum	WGS84(Default) total 219 datums
Time to First Fix	
Hot start	1 sec, average
Warm start	33 sec, average
Cold start	36 sec, average
Reacquisition	<1sec
Protocol	
GPS Output Data	NMEA 0183 (V3.01) - GGA, GLL ,GSA, GSV, RMC, VTG Baud rate 9600 bps, Data bit: 8, Stop bit: 1 (default)
Update Rate	1HZ(default)
1PPS	Enable (1Hz pulse 10% duty cycle)
Limitations	
Acceleration Limit	<4G
Altitude Limit	<18,000 meters
Velocity Limit	<515 meters/sec.
Jerk Limit	20 m/sec.
Power	
Operation Current	Acquisition: 55 mA Tracking: <30 mA (w/o Active ANT)
DC Input Range	VCC 3.0Vdc \pm 10% VBAT 1.0~1.5Vdc
Physical	
Dimension	12 x 12 x 3mm
Temperature	
Operating	-30°C ~ +85°C
Storage	-40°C ~ +125°C
Humidity	5% to 95% non-condensing
Antenna	
Impedance	50 Ω
Protection	Build-in Short circuit and Over current protection
Output Voltage	3.0VDC
Mounting	
SMT Type	18Pin

3 User Interface

EB-230 provides 2-wire digital UART port for communication of GPS position data using NMEA protocol or MTK extension protocol. UART port is capable of 4800 to 115200 baud rate. Additional 5-pin SPI port is provided for connection with external sensors such as compass, gyro...etc. SPI port share same pin location with general purpose input / output pins (pin #10 ~14).

3.1 Protocol

EB-230 is default to support standard NMEA-0183 protocol. In addition, a series of MTK extensions (PMTK messages) have been developed that can be used to provide extended capabilities common to many applications.

To achieve optimal compatibility it is intended to implement 100% compatible operating modes to existing protocols since these protocols are largely symmetrical and designed to provide a bi-directional exchange of data between GPS equipments.

3.1.1 NMEA Protocol

EB-230 is capable of supporting following NMEA formats:

NMEA Prefix	Format	Direction
\$GPGGA	GPS fix data	Out
\$GPGLL	Geographic position Latitude / Longitude	Out
\$GPGSA	GNSS DOP and active satellites	Out
\$GPGSV	Satellites in view	Out
\$GPRMC	Recommended minimum specific GNSS data	Out
\$GPVTG	Velocity and track over ground	Out
\$GPZDA	Date and time	Out

3.1.2 MTK NMEA Packet Format

Preamble	TalkerID	PktType	DataField	*	CHK1	CHK2	CR	LF
----------	----------	---------	-----------	---	------	------	----	----

Maximum packet length is restricted to 255 bytes.

Field	Length	Type	Description
Preamble	1 byte	Character	“\$”
TalkerID	4 byte	Character string	“PMTK”
PktType	3 byte	Character string	From “000” to “999”, an identifier used to tell the decoder how to decode the packet
DataField	Variable		A “,” must be inserted before each data field to help decoder process the DataField
*	1 byte	Character	The star symbol is used to mark the end of DataField
CHK1, CHK2	2 byte	Character string	Checksum of the data between preamble “,” and “*”
CR, LF	2 byte	Binary data	Used to identify the end of a packet

Sample Packet: \$PMTK000*32<CR><LF>

3.1.3 MTK NMEA Packet Protocol

In order to inform the sender whether the receiver has received the packet, an acknowledge packet PMTK_ACK should return after the receiver receives a packet.

3.1.4 MTK NMEA Packet List

Pkt Type	Abbreviation / Syntax	Data Field	Meaning / Example / Return
000	PMTK_TEST	None	Test Packet \$PMTK000*32<CR><LF>
001	PMTK_ACK PMTK001,Cmd,Flag	Cmd: Command / packet type the acknowledge responds Flag: 0 = Invalid command / packet 1 = Unsupported command / packet type 2 = Valid command / packet, but action failed 3 = Valid command / packet, and action succeeded	Acknowledge of PMTK command \$PMTK001,604,3*32<CR><LF>
010	PMTK_SYS_MSG PMTK001,Msg	Msg: System message. 0 : Unknown 1: Startup	Output system message \$PMTK010,001*2E<CR><LF>

Pkt Type	Abbreviation / Syntax	Data Field	Meaning / Example / Return
101	PMTK_CMD_HOT_START	None	Hot Restart: Use all available data in the NV storage \$PMTK101*32<CR><LF>
102	PMTK_CMD_WARM_START	None	Warm Restart: Don't use Ephemeris at re-start \$PMTK102*31<CR><LF>
103	PMTK_CMD_COLD_START	None	Cold Restart: Don't use Time, Position, Almanacs and Ephemeris data at re-start \$PMTK103*30<CR><LF>
104	PMTK_CMD_FULL_COLD_START	None	Essentially a Cold Restart, but additionally clear system/user configurations at re-start. Reset the receiver to factory default \$PMTK104*37<CR><LF>
251	PMTK_SET_NMEA_BAUDRATE PMTK251,Baudrate	Baudrate: Baud rate setting 0 – default setting, 4800, 9600, 14400, 19200, 38400, 57600, 115200	Set NMEA port baud rate \$PMTK251,38400*27<CR><LF>
300	PMTK_API_SET_FIX_CTL PMTK300,FixInterval,0,0,0,0	FixInterval: Position fix interval [msec]. Must be larger than 200	This parameter controls the rate of position fixing activity \$PMTK300,1000,0,0,0,0*1C<CR><LF>
301	PMTK_API_SET_DGPS_MODE PMTK301,Mode	Mode: DGPS data source mode. 0 : No DGPS source 1 : RTCM 2 : WAAS	DGPS correction data source mode \$PMTK301,1*2D<CR><LF>
313	PMTK_API_SET_SBAS_ENABLED	0 = Disable 1 = Enable	Enable to search a SBAS satellite or not \$PMTK313,1*2E<CR><LF>
314	PMTK_API_SET_NMEA_OUTPUT	See below note 1	Set NMEA sentence output frequency \$PMTK314,1,1,1,1,1,5,1,1,1,1,1,0,1,1,1,1,1*2C<CR><LF>
320	PMTK_API_SET_PWR_SAVING_MODE PMTK320,Mode (Internal testing ONLY)	Mode: 0: power saving mode off 1: power saving mode on	Set power saving operation mode \$PMTK320,0*26<CR><LF>
330	PMTK_API_SET_DATUM PMTK330,Datum	Datum: 0 : WGS84 1 : TOKYO-M 2 : TOKYO-A	Set default datum \$PMTK330,0*2E<CR><LF>
331	PMTK_API_SET_DATUM_ADVANCE PMTK331,majA,ecc,dX,dY,dZ	majA: User defined datum semi-major axis [m] ecc: User defined datum eccentric [m] dX: User defined datum to WGS84 X axis offset [m] dY: User defined datum to WGS84 X axis offset [m] dZ: User defined datum to WGS84 X axis offset [m]	Set user defined datum \$PMTK331, 6377397.155, 299.1528128, -148.0, 507.0,685.0*16<CR><LF>

Pkt Type	Abbreviation / Syntax	Data Field	Meaning / Example / Return
390	PMTK_API_SET_USER_OPTION PMTK390, Lock, Update_Rate, Baud_Rate, GLL_Period, RMC_Period, VTG_Period, GSA_Period, GSV_Period, GGA_Period, ZDA_Period, MCHN_Period	Lock: nonzero: freeze the setting; 0: allow further setting Update_Rate: 1~5 (Hz) Baud_Rate: 115200, 57600, 38400, 19200, 14400, 9600, 4800 XXX_Period: NMEA sentence output period	Write the user setting to the flash to override the default setting. Maximum 8 times without erase the chip. This feature may not be available \$PMTK390,1,1,38400,1,1,1,1,1,1,0*2B<CR><LF>
400	PMTK_API_Q_FIX_CTL	None	API_Query_Fix_Ctl \$PMTK400*36<CR><LF> PMTK_DT_FIX_CTL
401	PMTK_API_Q_DGPS_MODE	None	API_Query_Dgps_Mode \$PMTK401*37<CR><LF> PMTK_DT_DGPS_MODE
413	PMTK_API_Q_SBAS_ENABLED	None	API_Query_Sbas_Enabled \$PMTK413*34<CR><LF> PMTK_DT_SBAS_ENABLED
414	PMTK_API_Q_NMEA_OUTPUT	None	Query current NMEA sentence output frequencies \$PMTK414*33<CR><LF> PMTK_DT_NMEA_OUTPUT
420	PMTK_API_Q_PWR_SAVING_MODE (Internal testing ONLY)	None	Query power saving operation mode \$PMTK420*3F<CR><LF> PMTK_DT_PWR_SAVING_MODE
430	PMTK_API_Q_DATUM	None	Query default datum \$PMTK430*35<CR><LF> PMTK_DT_DATUM
431	PMTK_API_Q_DATUM_ADVANCE	None	Query user defined datum \$PMTK431*34<CR><LF> PMTK_DT_DATUM
490	PMTK_API_GET_USER_OPTION	None	Returns current user setting from flash memory. Refer to packet type 590 for detail \$PMTK490*33<CR><LF> PMTK_DT_FLASH_USER_OPTION
500	PMTK_DT_FIX_CTL	FixInterval: Position fix interval in msec [>= 200]	These parameters control the rate of position fixing activity \$PMTK500,1000,0,0,0,0*1A<CR><LF>
501	PMTK_DT_DGPS_MODE	Mode: DGPS data source mode 0 : No DGPS source 1 : RTCM 2 : WAAS	DGPS Data Source Mode \$PMTK501,1*2B<CR><LF>
513	PMTK_DT_SBAS_ENABLE	0 = Disable 1 = Enable	Enable to search a SBAS satellite or not \$PMTK513,1*28<CR><LF>
514	PMTK_DT_NMEA_OUTPUT	Total 19 data fields that present output frequency for the 19 supported NMEA sentences. Refer to packet type 314 for supported NMEA sentences and frequency	NMEA sentence output frequency setting \$PMTK514,1,1,1,1,1,5,1,1,1,1,1,0,1,1,1,1,1*2A<CR><LF>

Pkt Type	Abbreviation / Syntax	Data Field	Meaning / Example / Return
520	PMTK_DT_PWR_SAV_MODE PMTK520,Mode (Internal testing ONLY)	0: power saving mode off 1: power saving mode on	Power saving operation mode \$PMTK520,0*24<CR><LF>
530	PMTK_DT_DATUM PMTK530,Datum	0 : WGS84 1 : TOKYO-M 2 : TOKYO-A	Current datum used \$PMTK530,0*28<CR><LF>
590	PMTK_DT_FLASH_USER_OPTION	There are totally 11 data fields that present the followings: 1: Available number of times for recording the user setting. 2: Update_Rate: 1~5 3: Baud_Rate: in bps 4~11: NMEA sentence output period (GLL, RMC, VTG, GSA, GSV, GGA, ZDA, MCHN) 12: Datum 13: DGPS mode: 0 (disable), 1 (RTCM), 2 (SBAS) 14: RTCM baud rate in bps	The user setting in the flash memory \$PMTK590,0,1,9600,1,1,0,1,5,1,0,0,0,2,9600*2A<CR><LF>
604	PMTK_Q_VERSION	None	Query FW version \$PMTK604*6D<CR><LF> PMTK_DT_VERSION
605	PMTK_Q_RELEASE	None	Query FW release information \$PMTK605*31<CR><LF> PMTK_DT_RELEASE
704	PMTK_DT_VERSION PMTK704,FWVrsn1,FWVrsn2, FWVrsn3	Vrsn: MainVersion _ReleaseNumber	Version information of FW \$PMTK704,1.881_06,0606_m0138,0000*52<CR><LF>
705	PMTK_DT_RELEASE PMTK705,ReleaseStr,ModelID	ReleaseStr: Firmware release name & version ModelID: Model ID	Firmware release information \$PMTK705,Mcore_1.3,0000*15<CR><LF>

Note 1:

Total 19 data fields representing output frequency for each of the 19 supported NMEA sentences.

- 0 NMEA_SEN_GLL, // GPGLL interval - Geographic Position - Latitude longitude
- 1 NMEA_SEN_RMC, // GPRMC interval - Recommended Min. specific GNSS sentence
- 2 NMEA_SEN_VTG, // GPVTG interval - Course Over Ground and Ground Speed
- 3 NMEA_SEN_GGA, // GPGGA interval - GPS Fix Data
- 4 NMEA_SEN_GSA, // GPGSA interval - GNSS DOPS and Active Satellites
- 5 NMEA_SEN_GSV, // GPGSV interval - GNSS Satellites in View
- 6 NMEA_SEN_GRS, // GPGRS interval - GNSS Range Residuals
- 7 NMEA_SEN_GST, // GPGST interval - GNSS Pseudorange Error Statistics
- 13 NMEA_SEN_MALM, // PMTKALM interval - GPS almanac information
- 14 NMEA_SEN_MEPH, // PMTKEPH interval - GPS ephemeris information
- 15 NMEA_SEN_MDGP, // PMTKDGP interval - GPS differential correction information
- 16 NMEA_SEN_MDBG, // PMTKDBG interval - MTK debug information
- 17 NMEA_SEN_ZDA, // GPZDA interval - Time & Date
- 18 NMEA_SEN_MCHN, // PMTKCHN interval - GPS channel status

Support Frequency Setting :

- 0 - Disabled or not supported sentence
- 1 - Output once every one position fix

- 2 - Output once every two position fixes
- 3 - Output once every three position fixes
- 4 - Output once every four position fixes
- 5 - Output once every five position fixes

This command set GLL output frequency to be outputting once every 1 position fix, and RMC to be outputting once every 1 position fix, and so on.

You can also restore the system default setting via issue: `$PMTK314,-1*04<CR><LF>`

4 Dimension and Package

4.1 Mechanical Dimension

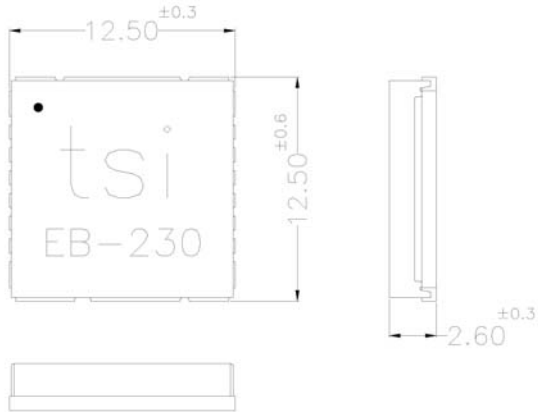

4.2 Recommend Layout Pattern

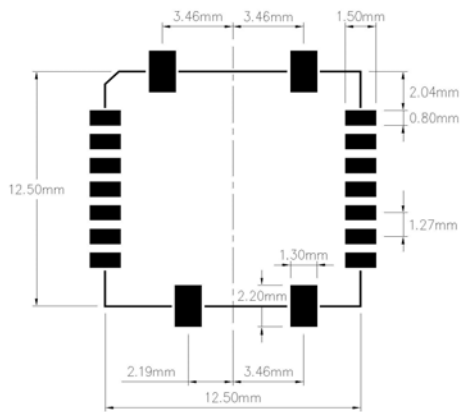

4.3 Package

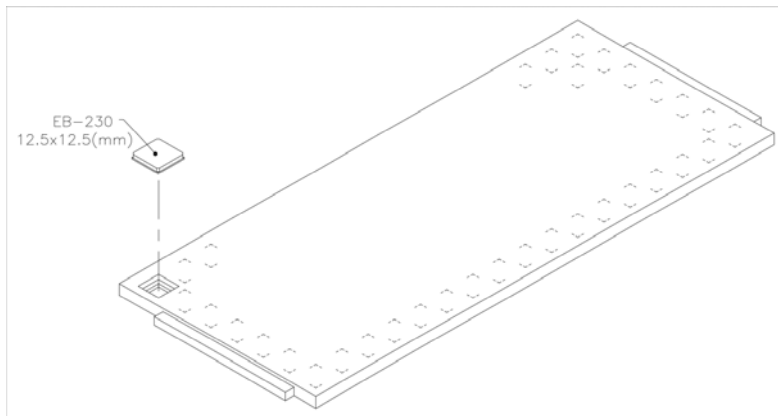

5 Application Information

5.1 GPS Antenna Recommendations

Follow below recommendations when choosing GPS antenna for EB-230 for best system performance. Transystem also offers active antenna products for optimal performance with EB-230. For details, please contact your Transystem sales contact directly.

- Use active antenna that works with 3V power supply
- Receiving frequency $1575.42 \pm 1.032\text{MHz}$
- Polarization RHCP (right hand circular polarized)
- Output impedance = 50 Ohm
- $15\text{dB} \leq \text{LNA Gain} \leq 20\text{dB}$
- Noise figure $\leq 2.0\text{dB}$
- Connector: surface mounted on main PCB, Ipex or MMCX

5.2 Application Circuit

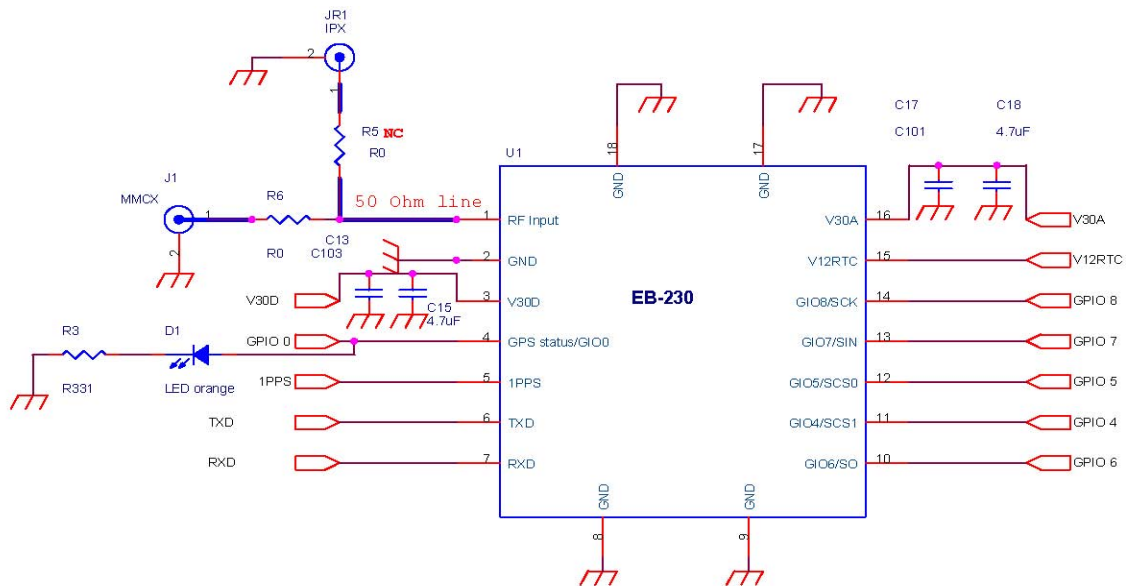

【Note1】 : GPS Status (pin#4) can be used as GPS position fix indicator.

【Note2】 : V12RTC (pin#15) could connect to 1.0 ~1.5Vdc power supply directly.

【Note3】 : Separate V30D (pin#3) from V30A (pin#16) for optimal performance.

5.3 General GPS Receiver User's Tips

- If the satellite signals can not be locked or experiencing receiving problem (while in urban area), following steps are suggested:
 - a) Please plug the external active antenna into GPS receiver and put the antenna outdoor or on the roof of the vehicle for better receiving performance.
 - b) Move to another open space or reposition GPS receiver toward the direction with least blockage.
 - c) Move the GPS receiver away from the interference sources.
 - d) Wait until the weather condition is improved.
- Some vehicles having heavy metallic sun protecting coating on windshields may affect signal receptions
- Driving in and around high buildings may affect signal reception.
- Driving under tunnels or in buildings may affect signal reception.
- In general, GPS receiver performs best in open space where it can see clean sky. Weather will affect GPS reception – rain & snow contribute to worsen sensitivity.
- When GPS receiver is moving, it will take longer time to get position fix. Wait for satellite signals to be locked at a fixed point when first power-on the GPS receiver to ensure quick GPS position fix.

Contact Information

Transystem Inc.
No. 1-2 Li-Hsin Rd. I,
Science-Based Industrial Park,
Hsinchu, Taiwan, R.O.C.
T : +886.3.578.0393
F : +886.3.578.4111
www.transystem.com.tw
gps.sales@transystem.com.tw