

# **SPK ELECTRONICS CO., LTD.**

10F, NO. 510, SEC. 5, CHUNG HSIAO E. RD.,

TAIPEI, TAIWAN, R.O.C.

E-Mail : [spktw@ms34.hinet.net](mailto:spktw@ms34.hinet.net) Web Site: <http://www.spkecl.com>

Tel: 886-2-23462323

Fax: 886-2-23463939

## **SPECIFICATION**

### Smart Antenna

### **SPK- GPS – GS405**



V. 1.0

Issue : September, 2006  
All Rights Reserved

---

## INDEX

<b>INDEX</b> .....	1
<b>1. FUNCTIONAL DESCRIPTION</b> .....	2
1.1. OVERVIEW.....	2
1.2. MAIN FEATURES.....	2
1.3. KEY BENEFITS.....	2
<b>2. SPECIFICATION</b> .....	3
2.1. ABSOLUTE MAXIMUM RATING.....	3
2.2. GEOHELIX-SMP GPS ANTENNA CHARACTERISTICS.....	3
2.3. GPS TECHNICAL SPECIFICATION.....	3
2.4. EXTERNAL BACKUP POWER CONDITIONS.....	4
2.5. SOFTWARE OPERATION CONDITION.....	4
2.6. COMMUNICATION SPECIFICATION.....	4
2.7. ENVIRONMENTAL CHARACTERISTICS.....	5
2.8. OTHER CHARACTERISTICS.....	5
2.9. PIN ASSIGNMENT AND DESCRIPTION.....	5
2.10. NMEA OUTPUT MESSAGES.....	6
2.10.1. SiRF NMEA Output Message.....	6
2.10.2. Protocol of NMEA Message.....	6
2.10.3. NMEA OUTPUT MESSAGES FORMAT.....	8
<b>3. DIMENSIONS</b> .....	11
<b>4. INTERFACE CONNECTOR</b> .....	12
<b>5. REFERENCE DESIGN</b> .....	12
<b>6. BOARD TO BOARD SMT TYPE CONNECTOR</b> .....	13

---

## 1. FUNCTIONAL DESCRIPTION

### 1.1. OVERVIEW

**SPK-GPS-GS405** is a Global Position System receiver module based on SiRF Star III high-sensitivity chipset solution which includes a built-in Sarantel omni-directional Geo-Helix SMP passive antenna. The receiver module can track 20 satellites simultaneously, integration with GPS receiver update navigation data every second and provide your exact location information soon after the power is turned on.

**SPK-GPS-GS405** designed for a broad spectrum of OEM personal positioning and navigation applications, such as hand-held or portable device. It will help you integrate to the system platform easily. **SPK-GPS-GS405** meets strict needs such as car navigation, mapping, surveying, security, agriculture and so on.

### 1.2. MAIN FEATURES

- Built-in SiRF Star III chipset with standard SiRF GSW 3.0 software
- Built-in Sarantel omni-directional Geo-helix SMP passive antenna, increases GSP signal reception sensitivity
- Twenty parallel satellites tracking channels for fast acquisition.
- A-GPS ready
- Compact size
- Support NMEA0183 V. 3.01 data protocol.
- TTL level output serial port easily for system on board integration

### 1.3. KEY BENEFITS

- Integrate GPS antenna and receiver
- Filtering effect of the antenna gives high immunity to RF interface
- High sensitivity GPS solution – Fast TTFF
- Wide antenna Beam width
- Simple integration and acceleration for time-to-market

# Specifications

## 2. SPECIFICATION

### 2.1. ABSOLUTE MAXIMUM RATING

Parameter	Min	Typ	Max	Units
Power Supply Voltage	3.1	3.3	3.5	V
Operating Current	67	75	82	mA

### 2.2. GEOHELIX-SMP GPS ANTENNA CHARACTERISTICS

Parameter	Min	Typ	Max	Unit
Frequency	1573.42	1575.42	1577.42	MHz
Gain	-5.5	-3.5		dBic
Beamwidth		>120		Degrees
VSWR		2.0:1	2.3:1	
Impedance		50		
Operating Temperature Range	-40	+20	+85	

### 2.3. GPS TECHNICAL SPECIFICATION

	ITEMS	DESCRIPTION
Chipset	GRF3w&GSP3f	SiRF StarIII technology
General	Frequency	L1, 1575.42 MHz
	C/A code	1.023 MHz chip rate
	Channels	20
Accuracy	Position	10 meters, 2D RMS
		5 meters 2D RMS, WAAS enabled
		< 5meters(50%), DGPS corrected
	Velocity	0.1 meters/second
Time	1 microsecond synchronized to GPS time	
Datum	Default	WGS-84
	Other	selectable for other Datum
Time to First Fix (Open Sky & Stationary Requirements)	Reacquisition	0.1 sec., average
	Snap start	1 sec., average
	Hot start	8 sec., average
	Warm start	38 sec., average
	Cold start	42 sec., average
Dynamic Conditions	Altitude	18,000 meters (60,000 feet) max.
	Velocity	515 meters/second (1000 knots) max.
	Acceleration	Less than 4g
	Jerk	20 meters/second <sup>3</sup> , max.

# Specifications

Power	Main power input	3.3 ± 5%V DC input.
	Power consumption	Less than 250 mW (Continuous mode)
	Supply Current	≈75 mA (Continuous mode)
	Backup Power	See section 2.9 PIN DESCRIPTION Pin#7
Serial Port	Electrical interface	One full duplex serial TTL UART interface.
	Protocol messages	NMEA-0183@4800 bps (Default)
Timemark-1PPS Pulse(Customization Device)	Level	TTL
	Pulse duration	100ms
	Time reference	At the pulse positive edge.
	Measurements	Aligned to GPS second, ±1 microsecond

## 2.4. EXTERNAL BACKUP POWER CONDITIONS

PARAMETER	Symbol	Min	Typ	Max	Units
RTC(Battery) Power	BATTERY		2.0	5.0	V
Supply Current			15		μA

## 2.5. SOFTWARE OPERATION CONDITION

ITEMS	DESCRIPTION	
Core of firmware	SiRF GSW version 3.0	
Baud rate	4800 (Default)	
Code type	NMEA-0183 ASCII	
Datum	WGS-84	
Protocol message	GGA, GSA, GSV, RMC / per second.	
Output frequency	1 Hz	
Acquisition Sensitivity	Cold start	28 dB-Hz (-143dBm)
	Warm start	28 dB-Hz
	Hot start (Standard)	15 dB-Hz
	Tracking	-159 dB

## 2.6. COMMUNICATION SPECIFICATION

PARAMETER	SPECIFICATION
Interface	Simple UART
Bit rate	4,800 bps
Start bit	1 bit
Stop bit	1 bit
Data bit	8 bit
Parity	None
Transmission data	NMEA 0183 Ver3.01

## 2.7. ENVIRONMENTAL CHARACTERISTICS

ITEM	MINIMUM	MAXIMUM
Operation conditions	-40	+85
Storage conditions	-55	+100

\* Operation humidity: 5 % to 90 % No condensing.

## 2.8. OTHER CHARACTERISTICS

	ITEMS	DESCRIPTION
Physical Characteristics	Length (with Antenna)	52mm (0.2in)
	Width	25.6mm (0.1in)
	Weight	≈16g

## 2.9. PIN ASSIGNMENT AND DESCRIPTIONS

### 2.9.1 PIN ASSIGNMENT

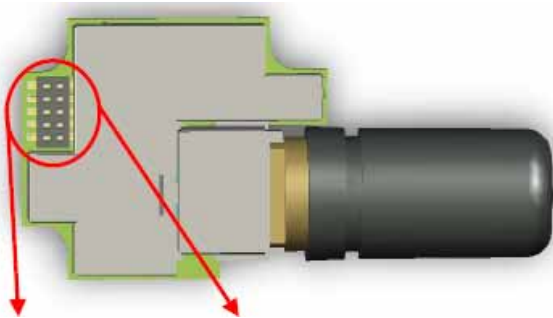

1	GND	GND	6
	VIN	BATTEY	
	GND	GND	
	GND	RX	
5	GPIO1	TX	10

# Specifications

## 2.9.2 PIN DESCRIPTIONS

PIN NO.	PIN NAME	I/O	REMARK
1	GND		Ground.
2	VIN	I	This is the main DC supply for a $3.3V \pm 5\%$ DC input power module board.
3	GND		Ground.
4	GND		Ground.
5	GPIO1	O	User can use this I/O pin for special function. For example, ON/OFF LED
6	GND		Ground.
7	BATTERY	I	This is the backup power input that powers the SRAM and RTC when main power is removed. Typical current draw is 15uA. Without an external backup battery, the module/engine board will execute a cold star after every turn on. To achieve the faster start-up offered by a hot or warm start, a backup battery must be connected. The battery voltage should be between 2.0v and 5.0v.
8	GND		Ground
9	RX	I	This is the main receive channel for receiving software commands to the engine board from SiRFdemo software or from user written software.
10	TX	O	This is the main transmits channel for outputting navigation and measurement data to user's navigation software or user written software. Output TTL level, 0V ~ 2.85V

### NOTE : BOARD TO BOARD CONNECTION

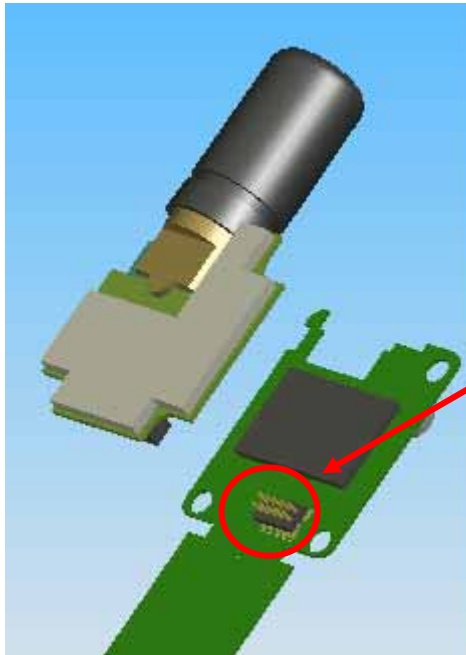

**Pin Header 1.27 mm (.050")**  
**Dual Row 2×5 H=2.0mm**

# Specifications

## 2.10. NMEA OUTPUT MESSAGES

### 2.10.1. SiRF NMEA Output Message

The unit output data is in NMEA-0183 format as defined by the *National Marine Electronics Association* (NMEA) Standard

### 2.10.2. Protocol of NMEA Message

This NMEA output message is designed to include:

**Start Sequence:** Start with character '\$' and behind it is the string representing message type.

**Payload:** Datum collected to output and being separated with comma.

**Checksum:** The value of checksum-algorithm.

Start Sequence	Payload	Checksum	End Sequence
----------------	---------	----------	--------------

#### Checksum

The checksum is two-byte in the payload data. The following pseudo code defines the algorithm used.

*Let message to be the array of bytes to be sent by the transport.*

*Index = 1*

*hecksum = 0*

*while message[ Index != '\*' ]*

*hecksum ^= message[ index++ ]*

Checksum will skip the '\$' character and then be calculated one character by one character using XOR(EXCLUSIVE-OR) operator to do so until getting '\*'

**Example :**

#### GGA—Global Positioning System Fixed Data

```
$GPGGA,161229.487,3723.2475,N,12158.3416,W,1,07,1.0,9.0,M,0.0,0000.18
```

GGA Data format

Name	Example	Units	Description
Message ID	\$GPGGA		GGA protocol header
UTC Time	161229.487		hhmmss.sss
Latitude	3723.2475		ddmm.mmmm
N/S Indicator	N		N=north or S=south
Longitude	12158.3416		dddmm.mmmm



# Specifications

E/W Indicator	W		E=east or W=west
Position Fix Indicator	1		<b>See Note</b>
Satellites Used	07		Range 0 to 12
HDOP	1.0		Horizontal Dilution of Precision
MSL Altitude <sup>1</sup>	9.0	meters	
Units	M	meters	
Geoid Separation <sup>1</sup>		meters	
Units	M	meters	
Age of Diff. Corr.		Second	Null fields when DGPS is not used
Diff. Ref. Station ID	0000		
Checksum	*18		
<CR> <LF>			End of message termination

Note : 1.Values are WGS84 ellipsoid heights.

**Note:** Position Fix Indicator

Value	Description
0	Fix not available or invalid
1	GPS SPS Mode, fix valid
2	Differential GPS, SPS Mode, fix valid
3	GPS PPS Mode, fix valid

### 2.10.3. NMEA OUTPUT MESSAGES FORMAT

MESSAGES	DESCRIPTION
<b>GGA</b>	Global positioning system fixed data
<b>GSA</b>	GNSS DOP and active satellites
<b>GSV</b>	GNSS satellites in view
<b>RMC</b>	Recommended minimum specific GNSS data

#### GGA —Global Positioning System Fixed Data

\$GPGGA,161229.487,3723.2475,N,12158.3416,W,1,07,1.0,9.0,M, , , ,0000\*18

Name	Example	Units	Description
Message ID	\$GPGGA		GGA protocol header
UTC Time	161229.487		hhmmss.sss
Latitude	3723.2475		ddmm.mmmm
N/S Indicator	N		N=north or S=south

# Specifications

Longitude	12158.3416		dddmm.mmmm
E/W Indicator	W		E=east or W=west
Position Fix Indicator	1		<b>See Note</b>
Satellites Used	07		Range 0 to 12
HDOP	1.0		Horizontal Dilution of Precision
MSL Altitude <sup>1</sup>	9.0	meters	
Units	M	meters	
Geoid Separation <sup>1</sup>		meters	
Units	M	meters	
Age of Diff. Corr.		Second	Null fields when DGPS is not used
Diff. Ref. Station ID	0000		
Checksum	*18		
<CR> <LF>			End of message termination

6. Values are WGS84 ellipsoid heights.

**Note:** Position Fix Indicator

Value	Description
0	Fix not available or invalid
1	GPS SPS Mode, fix valid
2	Differential GPS, SPS Mode, fix valid
3	GPS PPS Mode, fix valid

## GSA—GNSS DOP and Active Satellites

\$GPGSA,A,3,07,02,26,27,09,04,15, , , , , 1.8,1.0,1.5\*33

Name	Example	Units	Description
Message ID	\$GPGSA		GSA protocol header
Mode 1	A		See <b>Note1</b>
Mode 2	3		See <b>Note2</b>
Satellite Used <sup>1</sup>	07		Sv on Channel 1
Satellite Used <sup>1</sup>	02		Sv on Channel 2
.... ....			
Satellite Used <sup>1</sup>			Sv on Channel 12
PDOP	1.8		Position Dilution of Precision
HDOP	1.0		Horizontal Dilution of Precision
VDOP	1.5		Vertical Dilution of Precision
Checksum	*33		
<CR> <LF>			End of message termination

6. Satellite used in solution.

# Specifications

**Note 1**

Value	Description
M	Manual—forced to operate in 2D or 3D mode
A	2DAutomatic—allowed to automatically switch 2D/3D

**Note2**

Value	Description
1	Fix Not Available
2	2D
3	3D

**GSV—GNSS Satellites in View**

\$GPGSV,2,1,07,07,79,048,42,02,51,062,43,26,36,256,42,27,27,138,42\*71

\$GPGSV,2,2,07,09,23,313,42,04,19,159,41,15,12,041,42\*41

Name	Example	Units	Description
Message ID	\$GPGSV		GSV protocol header
Number of Messages <sup>1</sup>	2		Range 1 to 3
Message Number <sup>1</sup>	1		Range 1 to 3
Satellites in View	07		
Satellite ID	07		Channel 1 (Range 1 to 32)
Elevation	79	degrees	Channel 1 (Maximum 90)
Azimuth	048	degrees	Channel 1 (True, Range 0 to 359)
SNR (C/No)	42	dBHz	Range 0 to 99, null when not tracking
.... ..			
Satellite ID	27		Channel 4 (Range 1 to 32)
Elevation	27	degrees	Channel 4 (Maximum 90)
Azimuth	138	degrees	Channel 4 (True, Range 0 to 359)
SNR (C/No)	42	dBHz	Range 0 to 99, null when not tracking
Checksum	*71		
<CR> <LF>			End of message termination

6. Depending on the number of satellites tracked multiple messages of GSV data may be required.

**RMC—Recommended Minimum Specific GNSS Data**

\$GPRMC, 161229.487,A,3723.2475,N,12158.3416,W,0.13,309.62,120598, ,\*10

Name	Example	Units	Description
Message ID	\$GPRMC		RMC protocol header
UTC Time	161229.487		hhmmss.sss

# Specifications

Status	A		A=data valid or V=data not valid
Latitude	3723.2475		ddmm.mmmm
N/S Indicator	N		N=north or S=south
Longitude	12158.3416		dddmm.mmmm
E/W Indicator	W		E=east or W=west
Speed Over Ground	0.13	knots	
Course Over Ground	309.62	degrees	True
Date	120598		Ddmmyy
Magnetic Variation <sup>1</sup>		degrees	E=east or W=west
Checksum *10			
<CR> <LF>			End of message termination

1.All "course over ground" data are geodetic WGS84 directions.

### 3. DIMENSIONS

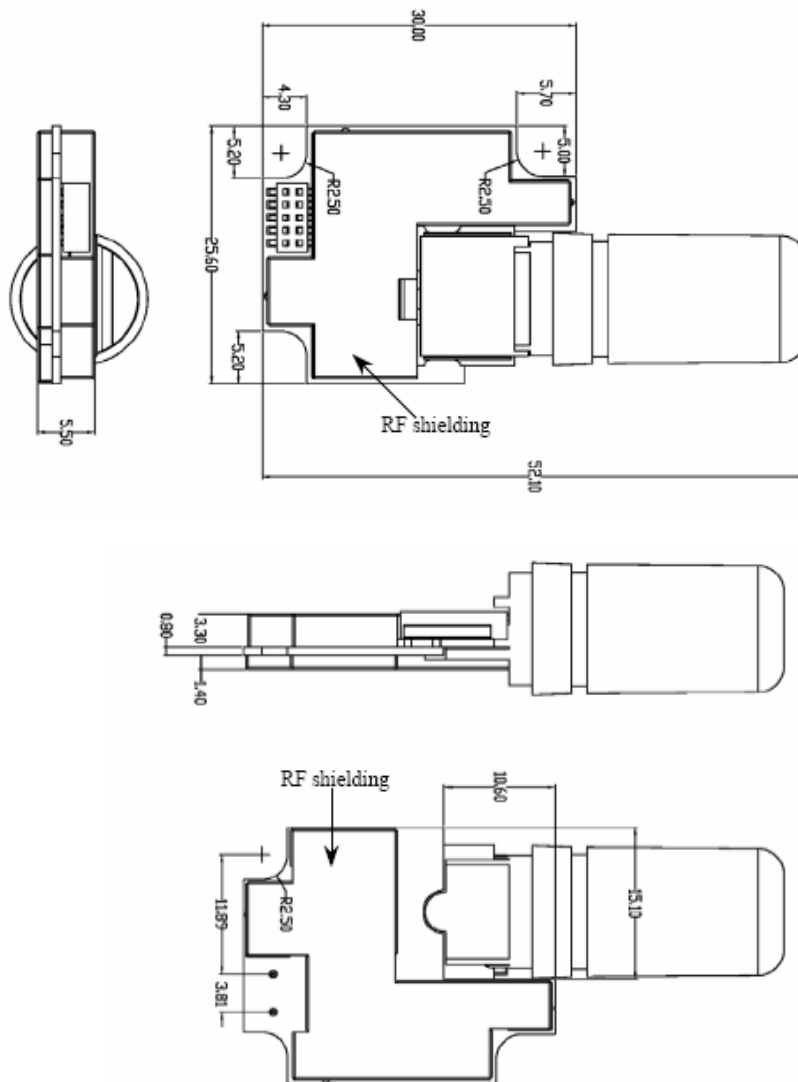

# Specifications

## 4. INTERFACE CONNECTOR

Female Header 1.27 mm (.050) Dual Row H=2.2 mm

## 5.REFERENCE DESIGN

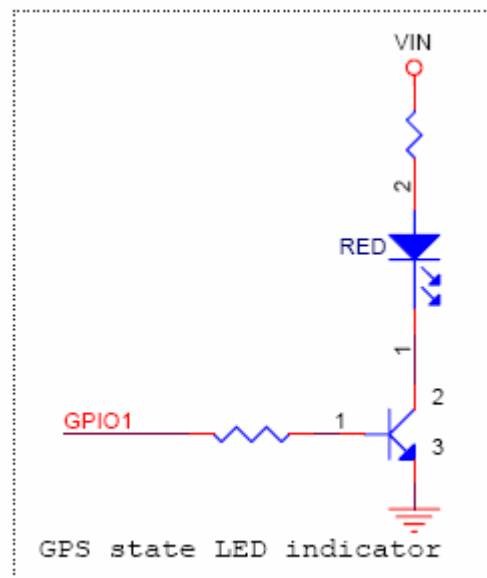
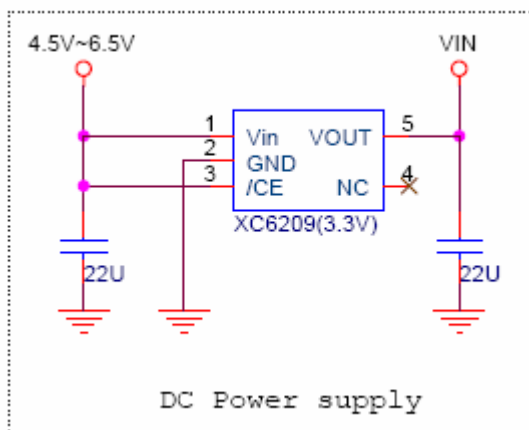
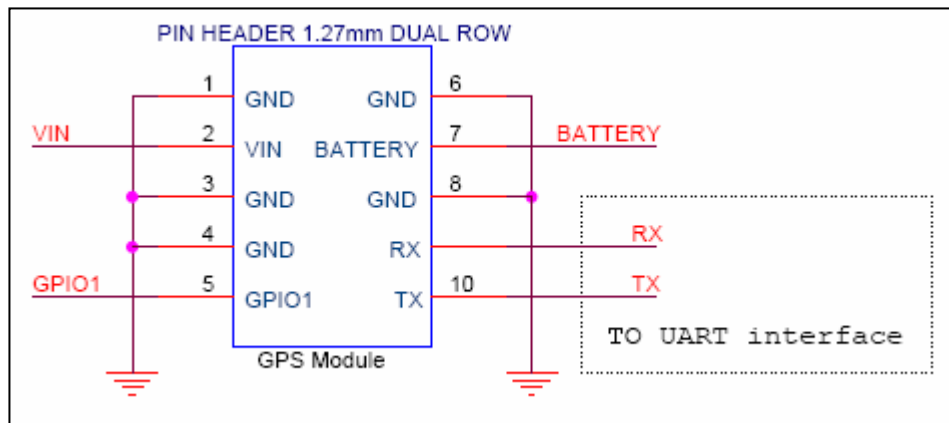
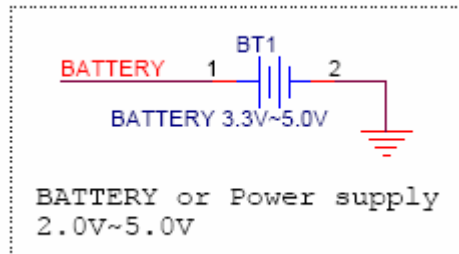

# Specifications

## 6. BOARD TO BOARD SMT TYPE CONNECTOR

**PIN Header 1.27 mm (.050") Dual Row 2x5 H=2.0 mm**

