

### Standard Features and Benefits

- High resolution and dynamic range
- Both digital (SPI) and analog outputs
- Low acceleration and angular rate cross sensitivity
- Low zero rate output drift
- Cost effective and compact solution
- High-performance MEMS sensor in mono crystalline Si yielding a superior long term behavior reliability and dynamic range
- Programmable bandwidth
- Factory set full scale range
- On chip EEPROM calibration
- Small footprint (SMD CLCC32) with horizontal mounting
- Operating temperature range: -40°C to 85°C

### Application

- Navigation (dead reckoning)
- Vehicle stability
- Robots

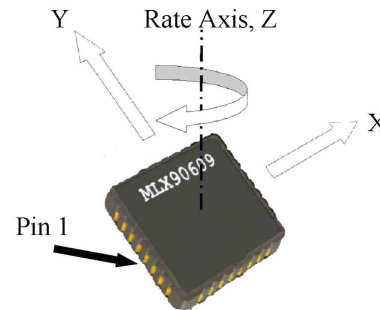

The MLX90609 has various build in features to support automotive and high volume applications (built-in on demand and non disruptive continuous self test, serial number in EEPROM...). These types of applications needs close cooperation between the customer and Melexis. Please contact Melexis in case you have such an application.

### Ordering Information

| Part No.       | Temperature Code  | Package Code | Option code | Full Scale Range |
|----------------|-------------------|--------------|-------------|------------------|
| MLX90609EEA-N2 | E (-40°C to 85°C) | EA (CLCC32)  | N2          | ±75 %/s          |
| MLX90609EEA-E2 | E (-40°C to 85°C) | EA (CLCC32)  | E2          | ±150 %/s         |
| MLX90609EEA-R2 | E (-40°C to 85°C) | EA (CLCC32)  | R2          | ±300 %/s         |

Note: Other Full Scale Ranges can be provided. Please contact Melexis.

### Functional Diagram

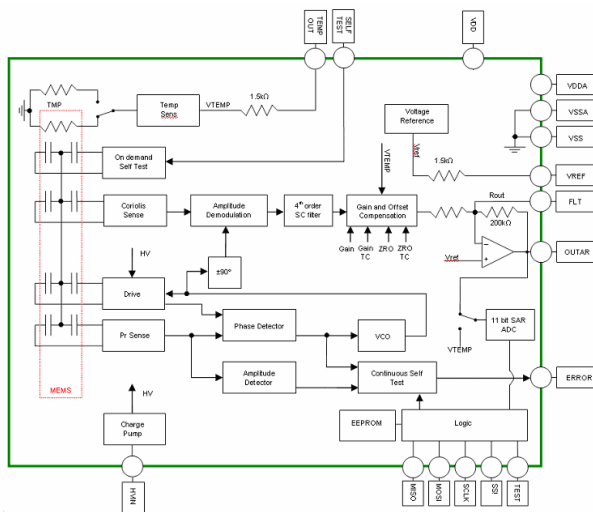

### General Description

The MLX90609 Angular Rate Sensor is a full gyroscopic system. A single SMD package contains a high performance silicon micro machined sensor with signal conditioning circuitry. It operates from 5V supply and is designed for demanding automotive applications.

The MLX90609 delivers two output signals proportional to the angular rate perpendicular to the assembly surface. One of the output signals is in an analog voltage format (the output is 2.5V at zero angular rate and the full scale angular rate produces an output of 4.5V or 0.5V depending on direction of rotation) and the other one is in digital SPI format.

**Table of Contents**

|  |    |
|--|----|
| 1. Maximum Ratings .....   | 3  |
| 2. Pin Definitions and Descriptions .....  | 4  |
| 3. MLX90609 General Electrical Specifications .....  | 5  |
| 4. MLX90609 Sensor Specific Specifications .....   | 6  |
| 5. Detailed Description .....  | 8  |
| 5.1 The Working Principle .....  | 8  |
| 5.2 Communication with the MLX90609 through the SPI .....  | 9  |
| 5.3 Usage of the ADC .....   | 12 |
| 5.3.1 ADC Instructions and Answers .....   | 13 |
| • The Refusal Answer .....   | 13 |
| • Command of the Status Reading (STATR) .....  | 13 |
| • Command of the ADC Control (ADCC) .....  | 13 |
| • Command of the ADC Reading (ADCR) .....  | 13 |
| 5.3.2 Reading the Digital Angular Rate or Temperature (suggested procedure) .....                                | 14 |
| 6. Applications Examples .....   | 15 |
| 7. Standard Information Regarding Manufacturability of Melexis Products with Different Soldering Processes ..... | 18 |
| 8. ESD Precautions .....   | 18 |
| 9. Package Information .....   | 19 |
| 10. Glossary of Terms .....  | 20 |
| 11. Disclaimer .....   | 22 |

### 1. Maximum Ratings

MLX90609 operates without failure, for 6500 hours with a certain temperature profile in the 40°C to +85°C range.

The MLX90609 meets the following maximum ratings over the entire operating temperature range and supply voltage range unless otherwise indicated. The current polarity is positive if the current flows into a terminal. All voltages are referenced to VSS.

| Parameter.  | Min  | Max   | Units | Comments  |
|---|------|-------|-------|---|
| Supply Voltage, VDD   | -0.5 | 7     | V     | No latch-up or damage.<br>Rise time (10 to 90%):<br>$t_r \geq 0.5\mu s$ . |
| Supply Voltage, VDD   | 4.75 | 5.25  | V     | Operating within specifications   |
| Output pins (OUTAR, OUTTEMP, all digital IO's) current limit, shorted to VDD or VSS pin |      | 25    | mA    | VDD = 0 to 7V<br>guaranteed by characterization                           |
| Operating Temperature Range, T <sub>AMBIENT</sub>                                       | -40  | 85    | °C    |   |
| Operating Temperature Range, T <sub>JUNCTION</sub>                                      | -40  | 110   | °C    | Output not shorted  |
| Storage Temperature Range   | -55  | 125   | °C    |   |
| Package Thermal Resistance  |      | 100   | °C/W  |   |
| Latch-up withstand  | -150 | 150   | mA    | CDF - AEC - Q100-004;<br>VDD= 5.75V                                       |
| Acceleration shock survival   |      | ±1500 | g     | Shock 0.5ms, 3 axis   |

**Table 1. Absolute maximum ratings**

Exceeding the absolute maximum ratings may cause permanent damage. Exposure to absolute-maximum-rated conditions for extended periods may affect device reliability.

### 2. Pin Definitions and Descriptions

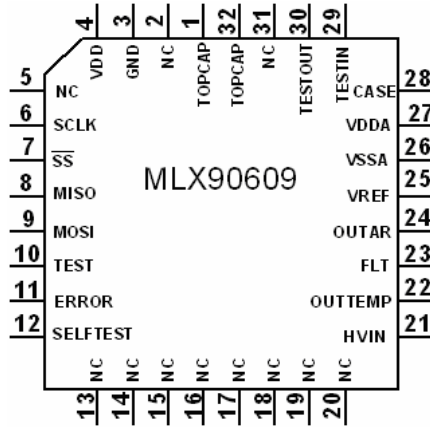

Figure 2-1. MLX90609 pin-out

| Group                     | Pin Name | Function   |
|---------------------------|----------|--|
| Power Supply Pins         | VSS      | Digital ground 0V  |
|                           | VDD      | Digital 5V   |
|                           | VDDA     | Analog Supply 5V   |
|                           | VSSA     | Analog ground, 0V, externally tied to digital ground                                       |
| Serial Communication Pins | SCLK     | Clock for serial data transfer, In, digital  |
|                           | MISO     | Master In, Slave Out   |
|                           | MOSI     | Master Out, Slave In   |
|                           | SS       | Slave/Chip select (active low)   |
| Factory Test Pins         | TEST     | Test-mode control pin (internal pull-down, In application tight to ground for EMC reasons) |
|                           | TESTIN   | In application tight to ground for EMC reasons   |
|                           | TESTOUT  | Do not connect   |
| User Diagnostic Pins      | SELFTEST | User on request self test input (for automotive applications)                              |
|                           | ERROR    | Continuous self test output (for automotive applications)                                  |
| Output Pins               | OUTAR    | Analog angular rate output   |
|                           | OUTTEMP  | Analog output of the temperature sensing module  |
| General purpose pins      | VREF     | 2.5V Output reference voltage  |
|                           | HVIN     | High voltage filter capacitor  |
|                           | FLT      | External capacitor for bandwidth setting   |
|                           | TOPCAP   | Tie to VSSA  |
|                           | CASE     | Tie to VSSA  |
|                           | NC       | Tie to VSSA  |
|                           | FLT      | External capacitor for bandwidth setting   |

Table 2. MLX90609 Pin description

### 3. MLX90609 General Electrical Specifications

DC Operating Parameters TA = -40°C to 85°C, VDD = 4.75V to 5.25V.

| Parameter.                                       | Symbol                  | Test Conditions                               | Min       | Typ | Max       | Units |
|--|-------------------------|---|-----------|-----|-----------|-------|
| Supply Voltage                                   | VDD                     |   | 4.75      |     | 5.25      | V     |
| Supply Current                                   | IDD                     | No output load                                |           | 16  | 20        | mA    |
| Output capacitive load to VDD or VSS             |                         | Analog output                                 | 0         |     | 100       | pF    |
| Output resistive load                            |                         | Analog output                                 | 200k      |     | ∞         | Ohm   |
| Output, max                                      | $U_{OUT, \Omega_{max}}$ | Analog output                                 |           | 4.5 |           | V     |
| Output, min                                      | $U_{OUT, \Omega_{min}}$ | Analog output                                 |           | 0.5 |           | V     |
| Voltage Reference load current <sup>Note 3</sup> | I <sub>REF</sub>        | Analog output                                 | -10       |     | 10        | μA    |
| Logic Input, Low Voltage                         | V <sub>IL</sub>         | $\overline{SS}$ , MOSI                        | 0         |     | 0.3 x VDD | V     |
| Logic Input, High Voltage                        | V <sub>IH</sub>         | $\overline{SS}$ , MOSI                        | 0.7 x VDD |     | VDD       | V     |
| Clock Input, Low Voltage                         | V <sub>ILC</sub>        | SCLK  | 0         |     | 0.8       | V     |
| Clock Input, High Voltage                        | V <sub>IHC</sub>        | SCLK  | 2.8       |     | VDD       | V     |
| Clock Input, Hysteresis Voltage                  | V <sub>HC</sub>         | SCLK  |           | 1.1 |           | V     |
| Logic Output, Low Voltage                        | V <sub>OL</sub>         | MISO, ERROR, I <sub>o</sub> < 8 mA            | 0         |     | 0.4       | V     |
| Logic Output, High Voltage                       | V <sub>OH</sub>         | MISO, ERROR, I <sub>o</sub> < 8 mA            | 2.4       |     | VDD       | V     |
| Input high current with pull-up                  | I <sub>IH_UP</sub>      | $\overline{SS}$ , SCLK, V <sub>IN</sub> = VDD | -10       |     | 10        | μA    |
| Input low current with pull-up                   | I <sub>IL_UP</sub>      | $\overline{SS}$ , SCLK, V <sub>IN</sub> = VSS | -10       |     | -200      | μA    |
| Input high current with pull-down                | I <sub>IH_DOWN</sub>    | MOSI, V <sub>IN</sub> = VDD                   | 200       |     | 10        | μA    |
| Input low current with pull-down                 | I <sub>IL_DOWN</sub>    | MOSI, V <sub>IN</sub> = VSS                   | -10       |     | 10        | μA    |
| Tri-State Output Leakage current                 | I <sub>oZ</sub>         | MISO  | -10       |     | 10        | μA    |

**Table 3. DC Electrical Characteristics**

### 4. MLX90609 Sensor Specific Specifications

DC Operating Parameters  $T_A = -40^\circ\text{C}$  to  $85^\circ\text{C}$ ,  $V_{DD} = 4.75\text{V}$  to  $5.25\text{V}$  (unless otherwise specified)

| Parameter   | Symbol   | Test Conditions  | Min | Typ                                | Max       | Units                                |
|---|--|--|-----|------------------------------------|-----------|--------------------------------------|
| Output Full Scale<br>(on OUTAR pin)                             | $FS_{OUT} = U_{OUT,\Omega\max} - U_{OUT,\Omega\min}$ |  |     | 4                                  |           | V                                    |
|   |  |  |     | 1920                               |           | LSB                                  |
| Full Scale Range  | $FS_{IN}$  | Factory set for N2 version<br>Factory set for E2 version<br>Factory set for R2 version   |     | $\pm 75$<br>$\pm 150$<br>$\pm 300$ |           | $^\circ/\text{s}$                    |
| Linearity <sup>Note 2</sup>                                     |  | Output, best fit based   |     |                                    | $\pm 0.5$ | % $FS_{OUT}$                         |
| Initial Scale Factor (sensitivity)                              | $S_0 = \frac{FS_{OUT}}{FS_{IN}}$                     | Data are given for N2, E2 and R2 versions respectively and according to the Full Scale Range Setting. At $25^\circ\text{C}$ , $V_{DD}=5\text{V}$ . |     | 26.67<br>13.33<br>6.67             |           | $\text{mV}/^\circ/\text{sec}$        |
|   |  |  |     | 12.8<br>6.4<br>3.2                 |           | $\text{LSB}/^\circ/\text{sec}$       |
| Scale Factor drift (sensitivity drift) <sup>Note 1</sup>        |  | $-40..+85^\circ\text{C}$ temperature range, supply voltage variation included  | -5  |                                    | 5         | % $S_0$                              |
| Zero Rate Output (Bias)   | ZRO  | at $25^\circ\text{C}$ , $V_{DD}=5\text{V}$   |     | 2.5                                |           | V                                    |
|   |  |  |     | 1008                               |           | LSB                                  |
| Zero Rate Temperature drift (Bias drift) <sup>Note 1</sup>      |  | $-40..+85^\circ\text{C}$ temperature range, $V_{DD}=5\text{V}$   | -5  | 0                                  | 5         | % $FS_{OUT}$                         |
| Zero Rate Supply Drift  |  | $4.75..5.25\text{V}$ at $25^\circ\text{C}$   |     | 250                                |           | $\text{mV}/\text{V}$                 |
|   |  |  |     | 120                                |           | $\text{LSB}/\text{V}$                |
| Bandwidth (-3 dB) <sup>Note 2</sup>                             |  | Selectable by external capacitor (section 6)   |     |                                    | 75        | Hz                                   |
| FLT to OUTAR capacitor value <sup>Note 2</sup>                  |  | 7 Hz Bandwidth (-4.5 to -1 dB)   |     | 100 $\pm 5\%$                      |           | nF                                   |
| Output Noise power spectral density                             |  | At $25^\circ\text{C}$  |     | 0.03                               |           | $^\circ/\text{sec}/\sqrt{\text{Hz}}$ |
| Angular Rate Cross-sensitivity for $O_x, O_y$ <sup>Note 2</sup> |  | for a full-scale angular rate along $O_x, O_y$   |     | 1                                  | 2         | % $FS_{OUT}$                         |

| Parameter                                  | Symbol             | Test Conditions  | Min  | Typ | Max  | Units |
|--|--------------------|--|------|-----|------|-------|
| Resonance Frequency                        | F <sub>RES</sub>   |  |      | 8.2 |      | KHz   |
| Wake-up time at power up <sup>Note 2</sup> |                    | MLX90609 operational, all parameters are in spec., C <sub>FLT</sub> =10nF, C <sub>3</sub> =100nF. Capacitors names are referred to Fig.6-1 |      | 150 | 250  | ms    |
| Resolution of the internal ADC             |                    |  |      | 11  |      | bit   |
| ADC conversion time <sup>Note 2</sup>      | T <sub>CONV</sub>  | Includes Track/Hold Acquisition Time   |      | 90  | 115  | μs    |
| Voltage Reference                          | V <sub>REF0</sub>  | at 25°C  | 2.45 | 2.5 | 2.55 | V     |
| Voltage Reference TC                       | TC <sub>VREF</sub> | $V_{REF} = V_{REF0} (1 + TC_{VREF} \times \Delta T)$   |      | 90  |      | ppm/K |
| Temperature Sensor                         | V <sub>TEMP0</sub> | at 25°C  | 2.3  | 2.5 | 2.7  | V     |
| Temperature Sensor TC                      | TC <sub>TEMP</sub> | $V_{OUTTEMP} = V_{TEMP0} + TC_{TEMP} \times \Delta T$  |      | 10  |      | mV/K  |

**Table 4. Sensor Specific Specifications**

**Notes:**

1. Better performance can be obtained. Please contact Melexis.
2. These numbers are guaranteed by design and/or characterization.
3. The voltage reference should ideally not be loaded, as there is an internal ESD resistor of about 1.5 kOhm in series with the output.

## 5. Detailed Description

### 5.1 The Working Principle

The MLX90609 is a Z-axis rate-sensing device, also called yaw-rate sensing. It produces an analog positive going output voltage for clockwise (CW) rotation around the axis normal to the package top, i.e., clockwise when looking down at the package lid as well as a digital SPI signal proportional to the angular rate.

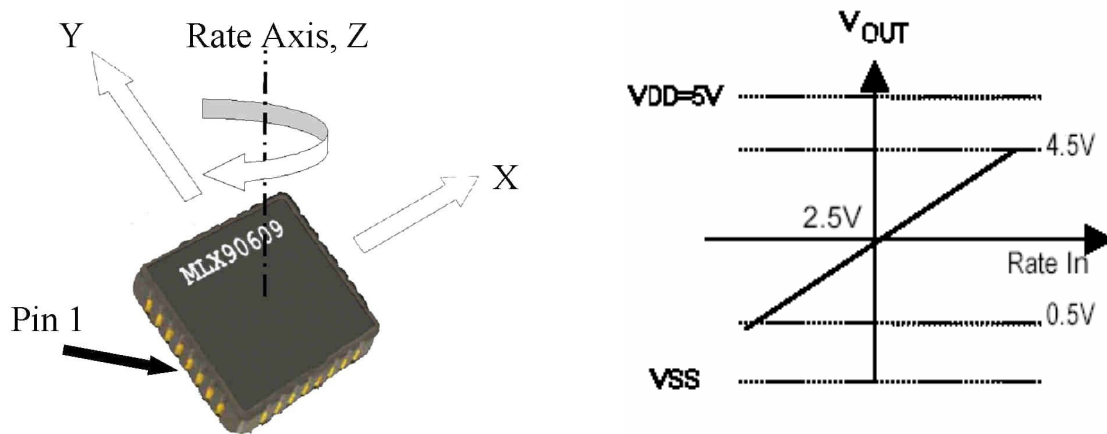

Figure 5-1. Angular rate (positive for clockwise rotation) to voltage output

The sensor is a MEMS gyroscope sensitive to Coriolis forces. To create a Coriolis force a movement must be induced. The gyro has an actuated oscillating mechanical structure (primary mode). The Coriolis force creates a second oscillating movement when the gyroscope rotates (secondary mode). As Coriolis force is usually extremely weak the primary mode is driven into resonance to keep the mechanical noise level low for the signal bandwidth used and to have a good sensitivity. A capacitance change in the secondary mode is detected and transformed into an output voltage by the electronic interface circuitry.

The electronic interface must convert a change in the sensor capacitance  $\Delta C$  into a change in transducer output voltage  $V_{OUT}$  according to the following transfer equation:

$$V_{OUT} = Bias + Gain * AngularRate$$

The bias and gain are adjustable over temperature in order to compensate for the TC of sensor and readout. After adjusting the bias and gain values and after setting operating mode switches during the calibration process the transducer output voltage versus angular rate must stay as shown in Figure 5-1 over the specified temperature range.



### 5.2 Communication with the MLX90609 through the SPI

The MLX90609 has a serial communication interface compatible with Serial Peripheral Interface (SPI). Likewise SPI the Serial Interface of the MLX90609 specifies four signals:

- serial clock (SCLK);
- master data output, slave data input (MOSI);
- master data input, slave data output (MISO); and
- slave select ( $\overline{SS}$ ).

The MLX90609 always operates as a slave. Therefore only MISO pin is an output.

The MLX90609 is selected when the  $\overline{SS}$  pin is low (see Figure 5-2). When  $\overline{SS}$  pin is high, data will not be accepted via the MOSI pin. The serial output pin (MISO) will remain in a high impedance state. High level of  $\overline{SS}$  forces the serial interface into the start state of data exchange.

Data is serially transmitted to the MLX90609 in 8 bit words (an instruction byte) and in 16 bit data words. Data is serially received from the MLX90609 in 16 bit words (an answer word). Most Significant Bit (MSB) is the first bit transmitted and received.

Transmission:

After the device is selected with  $\overline{SS}$  going low, the instruction byte will be received by the MLX90609. On each rising edge of SCLK data from MOSI enter into an internal 8-bit shift register. The accepted instruction byte contains the op-code that defines the operations to be performed. Along with op-code this byte can also contain information such as EEPROM address or ADC mode (to be setup).

Reception:

After the 8th bit is received to the shift register, the command will be executed by the MLX90609. The format of the outgoing data is defined by the received instruction. All instructions evoke an answer. A full communication cycle (transmitting an instruction and receiving the full answer) is finished after 24th clock of the SCLK. Communication can be terminated by putting  $\overline{SS}$  high.

Some remarks:

- If an invalid op-code is received, it is rejected and the corresponding data is ignored. In this case a special “*refusal answer*” will be generated.
- It's recommended to use synchronization by  $\overline{SS}$  after every data exchange to prevent a data distortion.
- If high level is applied to  $\overline{SS}$  during an instruction byte transmission, the command will be ignored.
- If high level is applied to  $\overline{SS}$  during the answer reception, the answer will be truncated. This can be used to limit the reading of the answer to e.g. one byte only (see Figure 5-3).

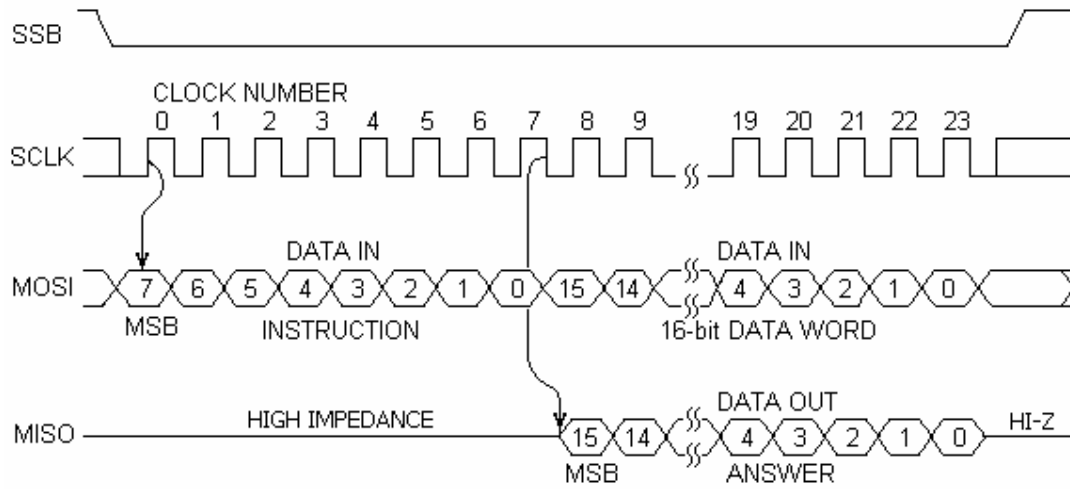

**Figure 5-2. Serial Exchange Sequence (full answer reading)**

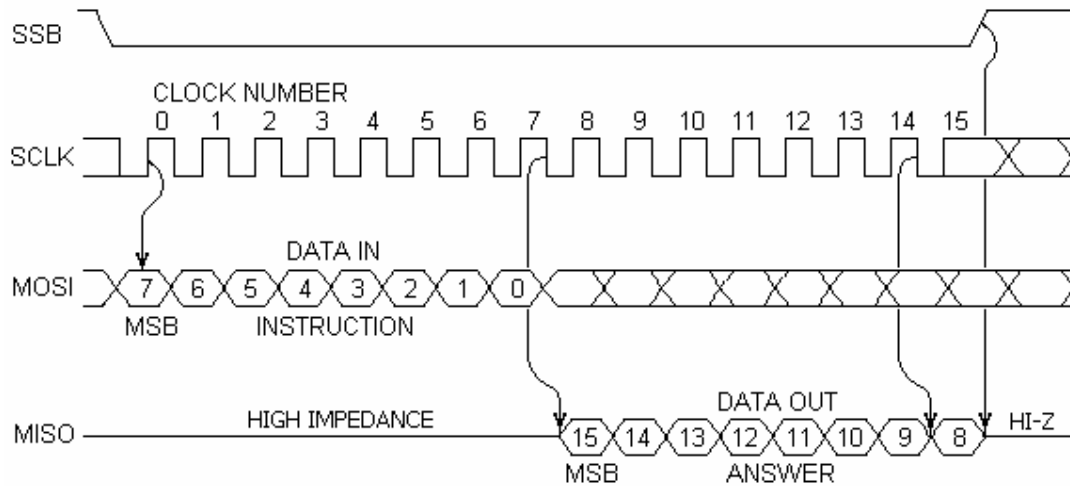

**Figure 5-3. Serial Exchange Sequence (the reading of the higher half of the answer)**

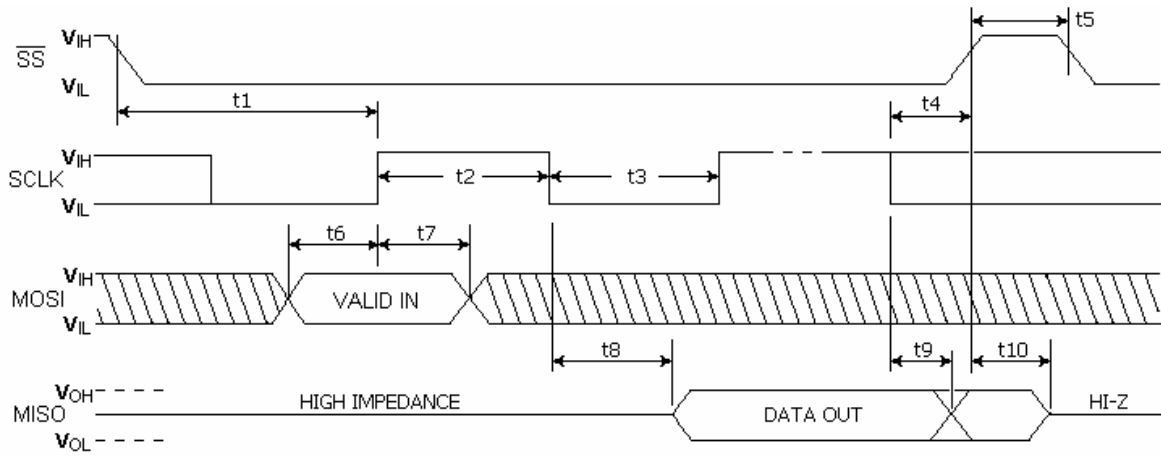

**Figure 5-4. Synchronous Data Timing**

| Parameter | Limit      | Units | Test Conditions/Comments                       |
|-----------|------------|-------|--|
| t1        | Minimum 30 | ns    | $\overline{SS}$ to SCLK Rising Edge Setup Time |
| t2        | Minimum 80 | ns    | SCLK High Duration                             |
| t3        | Minimum 80 | ns    | SCLK Low Duration                              |
| t4        | Minimum 0  | ns    | $\overline{SS}$ Hold Time                      |
| t5        | Minimum 50 | ns    | $\overline{SS}$ High Duration                  |
| t6        | Minimum 80 | ns    | Data In Setup Time                             |
| t7        | Minimum 50 | ns    | Data In Hold Time                              |
| t8        | Maximum 50 | ns    | Output Valid                                   |
| t9        | Minimum 0  | ns    | Output Hold Time                               |
| t10       | Maximum 40 | ns    | Output Disable Time                            |

**Table 5. SPI Timing Characteristics (see Figure 5-4)**

### 5.3 Usage of the ADC

The MLX90609 has the unique feature of simultaneously delivering an analog and a digital output signal.

The MLX90609 includes an internal 11-bit successive-approximation-register ADC with a sample-and-hold circuit and a programmable 2-channel analog multiplexer. The multiplexer connects the OUTAR pin or the OUTTEMP pin to the sample-and-hold circuit.

After a power-up the ADC is in a sleep mode. Before usage of the sleeping ADC it's recommended to use an initial dummy conversion. The result of this dummy conversion should be skipped but the next conversions will be valid. After conversions the ADC can be put in the sleep mode again.

A conversion must be initiated by means of the SPI command ADCC. This command turns the ADC on, sets a necessary channel and starts a conversion. To read a status of the conversion the ADCR or STATR commands can be used. As soon as the conversion is completed, its result should be read in the answer of the command ADCR (see tables 8, 9 and 10).

There are two conversion formulas below. The formulas reflect the typical ADC behavior and can be used to evaluate the voltage on the OUTAR and OUTTEMP pins:

$$V_{OUTAR} (mV) = \frac{25}{12} ADCcode + 400$$

$$V_{OUTTEMP} (mV) = \frac{25}{16} ADCcode + 300$$

The ADCcode represents the 11-bit result of the conversion (see Table 10).

Table 6 gives a description of the bits that are mentioned in this section.

|             |   |
|-------------|---|
| <b>ADEN</b> | The ADEN bit selects the power management mode of the ADC:<br>ADEN=0: ADC is switched to the sleep mode, no AD-conversion is allowed.<br>ADEN=1: AD-conversion is allowed.<br>This bit is set by the ADCC-command. After power-up bit ADEN is cleared.                    |
| <b>BUSY</b> | This bit will be set after a reset and will be toggled to zero after all initialization procedures inside the MLX90609. While BUSY=1, only refusal answers will be sent.  |
| <b>CHAN</b> | The CHAN bit is used to select the input source for the ADC.<br>CHAN=0: the angular rate channel.<br>CHAN=1: the temperature sensor channel.<br>This bit is set by the ADCC-command. After power-up bit CHAN is cleared.  |
| <b>EOC</b>  | End of AD-conversion bit. EOC bit indicates an ADC state.<br>EOC=0 : ADC in progress and can not be restarted.<br>EOC=1 : AD-conversion has been completed and can be restarted.<br>As a result, any attempt of the ADC starting will be rejected if EOC has a "0" state. |
| <b>OPC</b>  | Unknown Operation Code. This bit is set when a received operation code was not recognized.  |
| <b>X</b>    | These bits are reserved or have an undefined state.   |

**Table 6. SPI bits**

### 5.3.1 ADC Instructions and Answers

There are three SPI commands that are used to control embedded ADC of the MLX90609: STATR, ADCC and ADCR.

- **The Refusal Answer**

Every instruction sent to the MLX90609 has an answer. If the MLX90609 is not able to accept the instruction a refusal answer will be transmitted out. This answer has a unique format which is shown in the Table 7. The refusal answer is the only one that has a set MSB. The other bits help to understand a possible reason for the instruction rejection.

| Refusal answer |       |       |       |       |       |       |       |       |       |       |       |       |       |       |       |
|----------------|-------|-------|-------|-------|-------|-------|-------|-------|-------|-------|-------|-------|-------|-------|-------|
| Bit15          | Bit14 | Bit13 | Bit12 | Bit11 | Bit10 | Bit 9 | Bit 8 | Bit 7 | Bit 6 | Bit 5 | Bit 4 | Bit 3 | Bit 2 | Bit 1 | Bit 0 |
| 1              | OPC   | EOC   | X     | X     | BUSY  | X     | X     | X     | X     | X     | X     | X     | X     | X     | X     |

**Table 7. Refusal answer format**

- **Command of the Status Reading (STATR)**

| Instruction |       |       |       |       |       |       |       |
|-------------|-------|-------|-------|-------|-------|-------|-------|
| Bit 7       | Bit 6 | Bit 5 | Bit 4 | Bit 3 | Bit 2 | Bit 1 | Bit 0 |
| 1           | 0     | 0     | 0     | 1     | 0     | 0     | 0     |

| Answer |       |       |       |       |       |       |       |       |       |       |       |       |       |       |       |
|--------|-------|-------|-------|-------|-------|-------|-------|-------|-------|-------|-------|-------|-------|-------|-------|
| Bit15  | Bit14 | Bit13 | Bit12 | Bit11 | Bit10 | Bit 9 | Bit 8 | Bit 7 | Bit 6 | Bit 5 | Bit 4 | Bit 3 | Bit 2 | Bit 1 | Bit 0 |
| 0      | X     | EOC   | X     | X     | X     | X     | X     | X     | X     | X     | X     | CHAN  | ADEN  | X     | X     |

**Table 8. Format of the STATR command**

- **Command of the ADC Control (ADCC)**

| Instruction |       |       |       |       |       |       |       |
|-------------|-------|-------|-------|-------|-------|-------|-------|
| Bit 7       | Bit 6 | Bit 5 | Bit 4 | Bit 3 | Bit 2 | Bit 1 | Bit 0 |
| 1           | 0     | 0     | 1     | CHAN  | ADEN  | 0     | 0     |

| Answer |       |       |       |       |       |       |       |       |       |       |       |       |       |       |       |
|--------|-------|-------|-------|-------|-------|-------|-------|-------|-------|-------|-------|-------|-------|-------|-------|
| Bit15  | Bit14 | Bit13 | Bit12 | Bit11 | Bit10 | Bit 9 | Bit 8 | Bit 7 | Bit 6 | Bit 5 | Bit 4 | Bit 3 | Bit 2 | Bit 1 | Bit 0 |
| 0      | X     | EOC   | X     | X     | X     | X     | X     | X     | X     | X     | X     | CHAN  | ADEN  | X     | X     |

**Table 9. Format of the ADCC command (The answer is the same as for the STATR command)**

- **Command of the ADC Reading (ADCR)**

| Instruction |       |       |       |       |       |       |       |
|-------------|-------|-------|-------|-------|-------|-------|-------|
| Bit 7       | Bit 6 | Bit 5 | Bit 4 | Bit 3 | Bit 2 | Bit 1 | Bit 0 |
| 1           | 0     | 0     | 0     | 0     | 0     | 0     | 0     |

| Answer     |       |   |       |       |       |       |       |       |       |       |       |       |       |       |       |
|------------|-------|---|-------|-------|-------|-------|-------|-------|-------|-------|-------|-------|-------|-------|-------|
| Bit15      | Bit14 | Bit13   | Bit12 | Bit11 | Bit10 | Bit 9 | Bit 8 | Bit 7 | Bit 6 | Bit 5 | Bit 4 | Bit 3 | Bit 2 | Bit 1 | Bit 0 |
| 0          | X     | EOC   | X     | AD10  | AD9   | AD8   | AD7   | AD6   | AD5   | AD4   | AD3   | AD2   | AD1   | AD0   | 0     |
| AD10...AD0 |       | A result of the AD-conversion. These bits are valid only when EOC bit is set. |       |       |       |       |       |       |       |       |       |       |       |       |       |

**Table 10. Format of the ADCR command**

### 5.3.2 Reading the Digital Angular Rate or Temperature (suggested procedure)

There is a recommended sequence below to obtain digital data from the ADC.

Notes:

- The bit with leftmost position should be shifted first.
- Below "x" means any value: "0" or "1".

- **Step 1 (put ADC to the active mode if it wasn't)**

Use SPI to send ADCC instruction (MOSI): 1 0 0 1 x 1 0 0 x x x x x x x x x x x x x x x x  
 And check 15th bit of the answer (MISO): 0 x x x x x x x x x x x x x x x  
 If 15<sup>th</sup> bit is zero, the instruction is accepted.  
 Before to go to the Step 2 provide a delay > 115 µs or wait till the EOC bit is set.

- **Step 2 (conversion start)**

Use SPI to send ADCC instruction(MOSI):1 0 0 1 CHAN 1 0 0 x x x x x x x x x x x x x x x x  
 And check 15th bit of the answer (MISO): 0 x x x x x x x x x x x x x x x  
 If 15<sup>th</sup> bit is zero, the instruction is accepted.  
 CHAN bit specifies the input source of the ADC.  
 CHAN=0: The angular rate signal.  
 CHAN=1: The temperature sensor signal.  
 Go to the Step 3.

- **Step 3 (polling and result obtaining)**

Use SPI to send ADCR instruction and check 15<sup>th</sup> and 13<sup>th</sup> bits of the answer:  
1 0 0 0 0 0 0 0 x x x x x x x x x x x x x x x x  
0 x EOC x AD10 AD9 AD8 AD7 AD6 AD5 AD4 AD3 AD2 AD1 AD0 0

If 15<sup>th</sup> bit is zero, the instruction is accepted.  
 If 13<sup>th</sup> bit (EOC) is zero, the conversion is still in progress and the result of the conversion (bits AD10...AD0) is not valid. As soon as the EOC bit is set the conversion is completed and the result is valid.  
 Instead of the polling of the EOC bit one can use a simple delay that should be bigger than a maximal conversion time (>115 µs, see table 4).  
 Go to the Step 2 to do the next conversion or to the Step 4 to put ADC to the sleep mode.

- **Step 4 (put ADC to the sleep mode if it's necessary)**

Use SPI to send ADCC instruction (MOSI): 1 0 0 1 x 0 0 0 x x x x x x x x x x x x x x x x  
 And check 15th bit of the answer (MISO): 0 x x x x x x x x x x x x x x x  
 If 15<sup>th</sup> bit is zero, the instruction is accepted.

## 6. Applications Examples

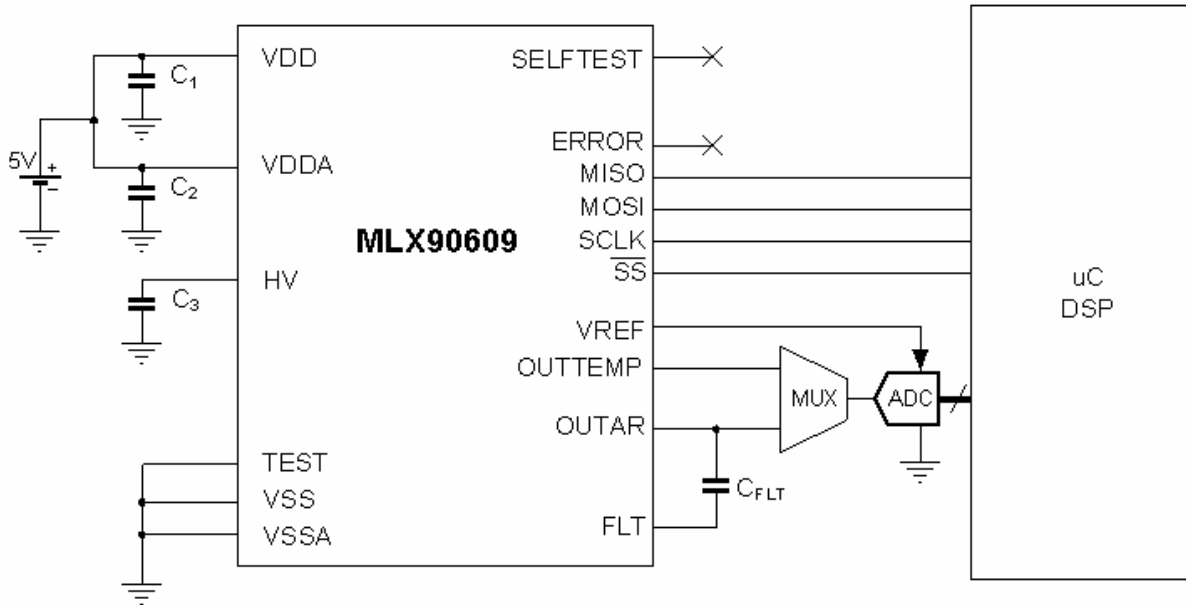

Figure 6-1. MLX90609 with simultaneous analog and digital output

The MLX90609 can simultaneously output analog and digital signals.

The analog output signal can be fed to a microcontroller ( $\mu\text{C}$ ) that contains an analog-to-digital converter. A multiplexer can be used to select between the temperature and the angular rate signals. The MLX90609 generates an internal reference voltage used for supplying the ADC, thereby maintaining accuracy regardless of the supply voltage of the  $\mu\text{C}$ .

Whilst supplying the analog output signal, the MLX90609 can simultaneously send a digital output signal to the  $\mu\text{C}$  through the SPI.

Notes:

1. The bandwidth of the MLX90609 can be selected by connecting an appropriate capacitor in the FLT pin.  $C_{\text{FLT}}$  implements a first order low pass filter cascaded with an internal 4-th order SC filter. The  $-3\text{dB}$  bandwidth set by  $C_{\text{FLT}}$  is:  $f_{\text{OUT}} = 0.16 / (R_{\text{OUT}} * C_{\text{FLT}})$ , with  $R_{\text{OUT}} = 200\text{k}\Omega$  (typ). It is recommended to use  $C_{\text{FLT}}$  even if the cut-off frequency is not specified to reduce switching spikes at the output.
2. It is recommended to use X5R or X7R type capacitors. Min. voltage for  $C_3$  should be 25V or more, and 10V or more for the other capacitors. Recommended values of decoupling capacitors  $C_1$  and  $C_2$  are  $1.0\mu\text{F}$  and  $0.1\mu\text{F}$  for  $C_3$ . These capacitors should be placed as close as possible to their respective pins.
3. HVIN is a high impedance node. Be sure that an equivalent leakage resistance at this node isn't less than  $2\text{M}\Omega$

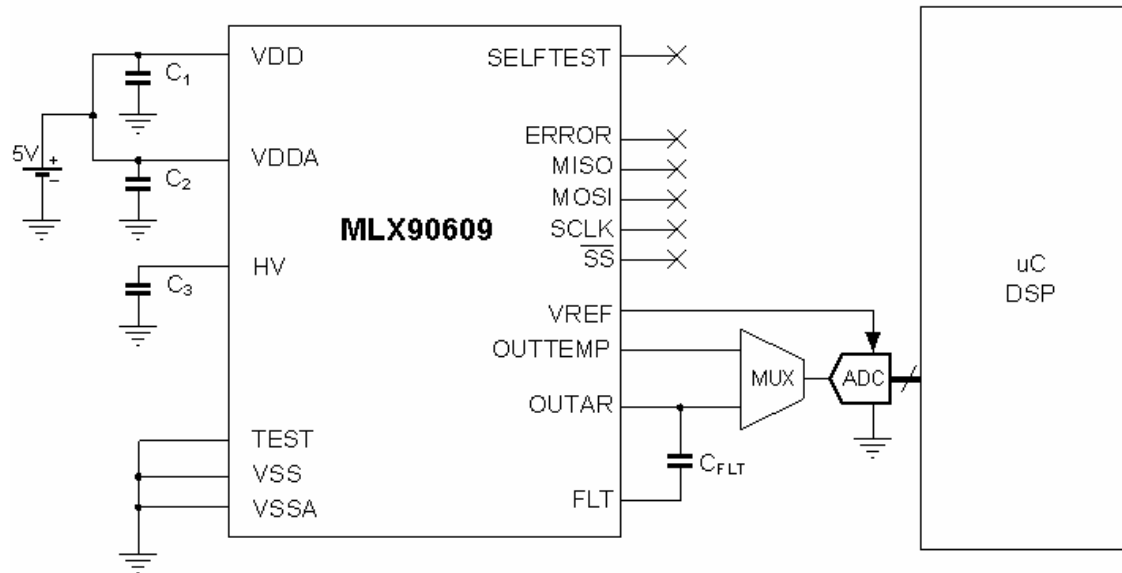

**Figure 6-2. MLX90609 with analog output only**

If only an analog output signal is required, the MLX90609 doesn't need to communicate through the SPI pins. All other pins continue to be used as described above.

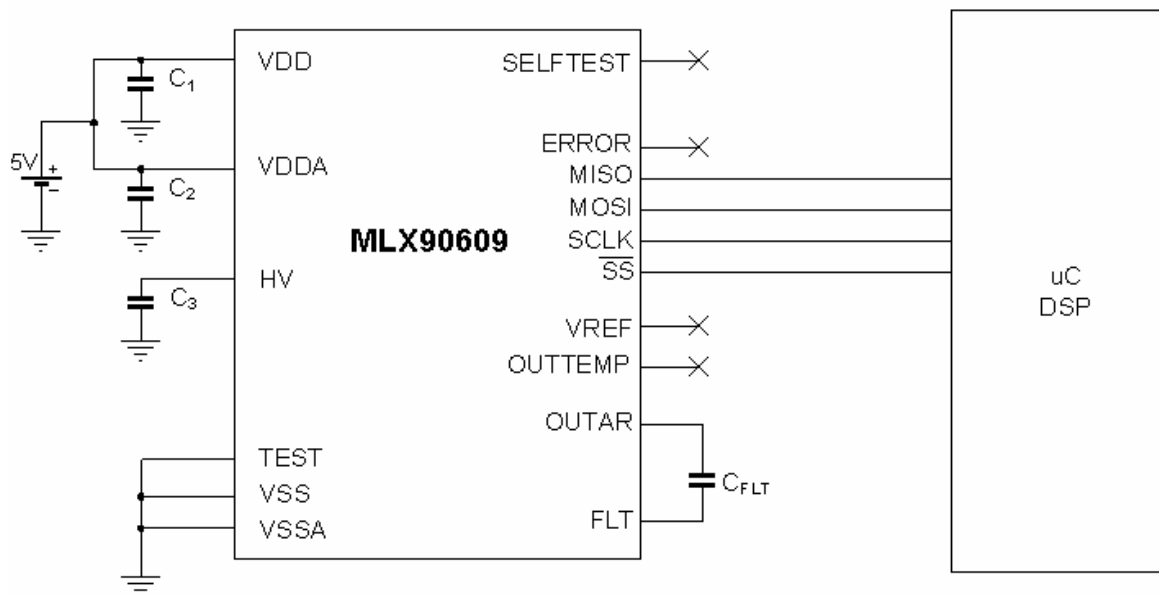
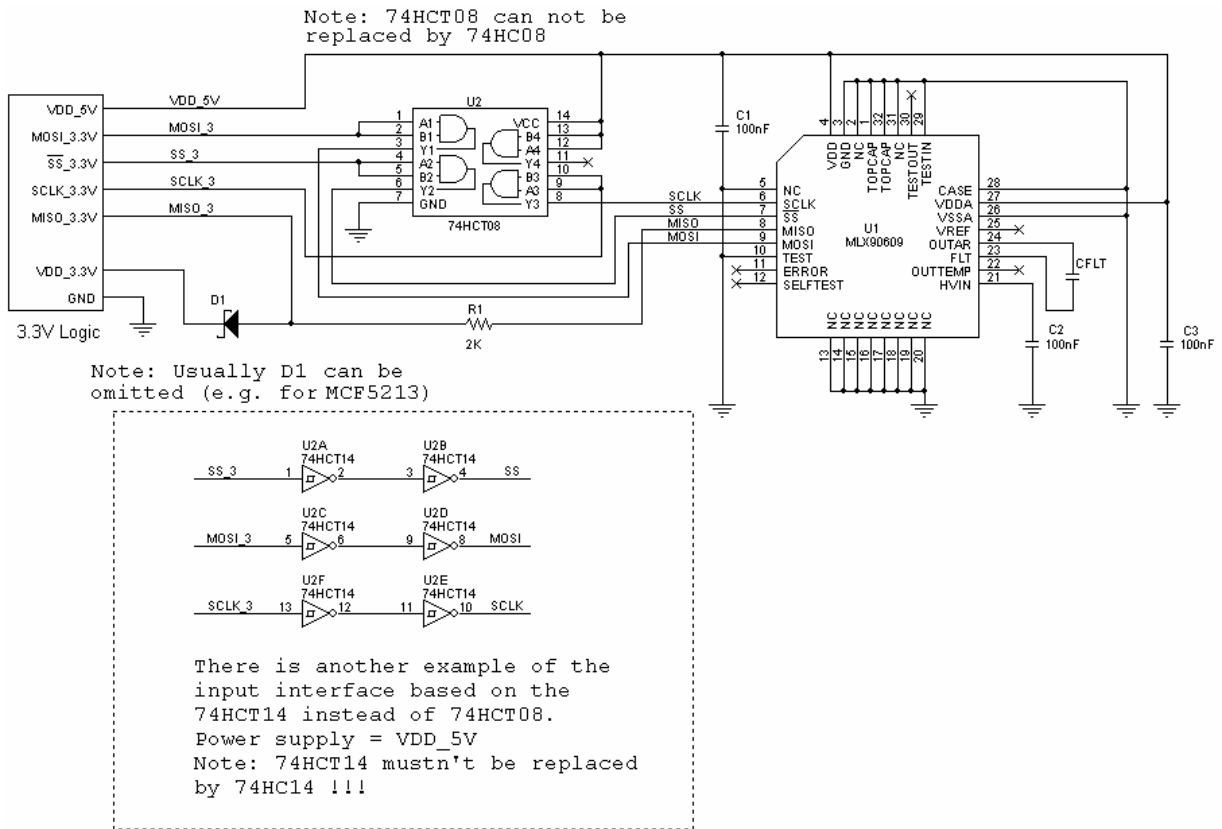

**Figure 6-3. MLX90609 with digital output only**

If only a digital output signal is required the MLX90609 uses the SPI to send the temperature and the angular rate in a digital format. The operation mode only through the SPI allows a reduction of cost and complexity in the interfacing to system microcontroller or microprocessor. All the pins in the above schematics continue to be used as described above.



In order to adapt the MLX90609 for a 3.3V Microcontroller one can use the below schematic:



**Figure 6-4. Possible interfacing with 3.3V  $\mu$ C**

## **7. Standard Information Regarding Manufacturability of Melexis Products with Different Soldering Processes**

Our products are classified and qualified regarding soldering technology, solderability and moisture sensitivity level according to following test methods:

### **Reflow Soldering SMD's (Surface Mount Devices)**

- IPC/JEDEC J-STD-020  
Moisture/Reflow Sensitivity Classification for Nonhermetic Solid State Surface Mount Devices  
(Classification reflow profiles according to table 5-2)
- EIA/JEDEC JESD22-A113  
Preconditioning of Nonhermetic Surface Mount Devices Prior to Reliability Testing  
(Reflow profiles according to table 2)

### **Wave Soldering SMD's (Surface Mount Devices) and THD's (Through Hole Devices)**

- EN60749-20  
Resistance of plastic- encapsulated SMD's to combined effect of moisture and soldering heat
- EIA/JEDEC JESD22-B106 and EN60749-15  
Resistance to soldering temperature for through-hole mounted devices

### **Iron Soldering THD's (Through Hole Devices)**

- EN60749-15  
Resistance to soldering temperature for through-hole mounted devices

### **Solderability SMD's (Surface Mount Devices) and THD's (Through Hole Devices)**

- EIA/JEDEC JESD22-B102 and EN60749-21

Solderability

For all soldering technologies deviating from above mentioned standard conditions (regarding peak temperature, temperature gradient, temperature profile etc) additional classification and qualification tests have to be agreed upon with Melexis.

The application of Wave Soldering for SMD's is allowed only after consulting Melexis regarding assurance of adhesive strength between device and board.

## **8. ESD Precautions**

Electronic semiconductor products are sensitive to Electro Static Discharge (ESD).

Always observe Electro Static Discharge control procedures whenever handling semiconductor products.

**9. Package Information**

The MLX90609 is packaged in a 32 pin JESD30C compliant Ceramic Quad Flat None leaded - CQFN32 -ceramic housing. The CQFN32 is commonly called CLCC32 or LCCC32.

Note: All dimensions are given in mm (inch).

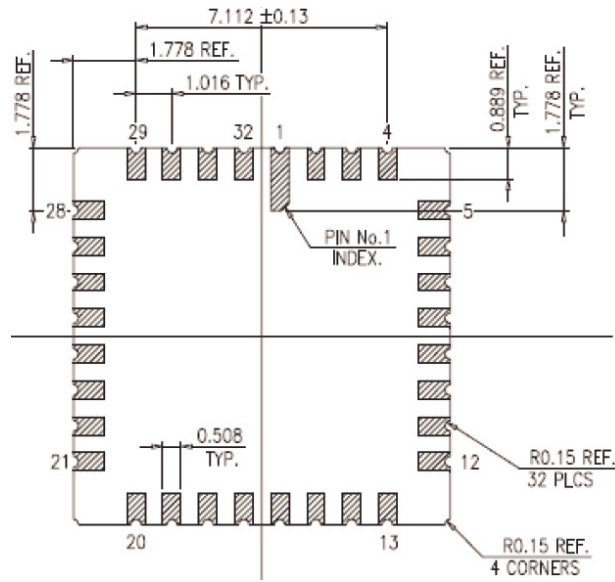

**Figure 9-1. Package Dimensions, Bottom View**

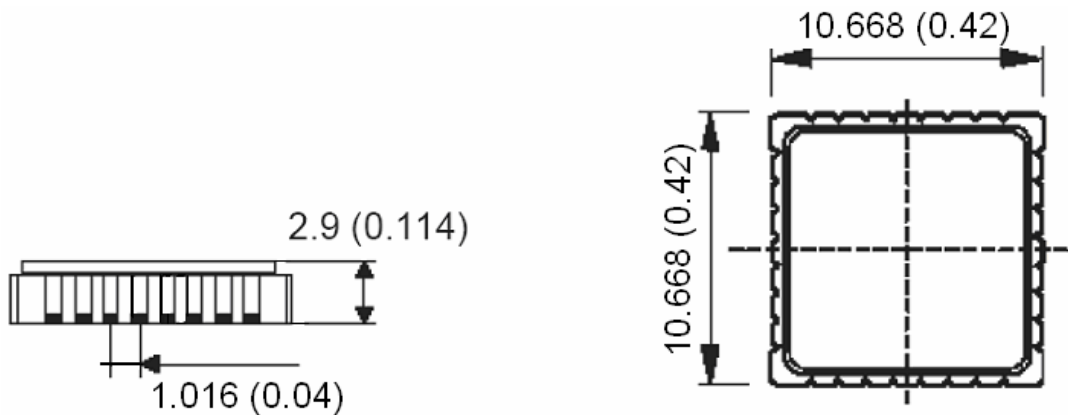

**Figure 9-2. Side and Top View of the MLX90609**

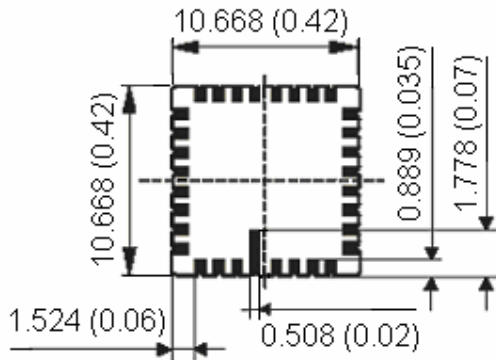

Figure 9-3. MLX90609 Bottom View

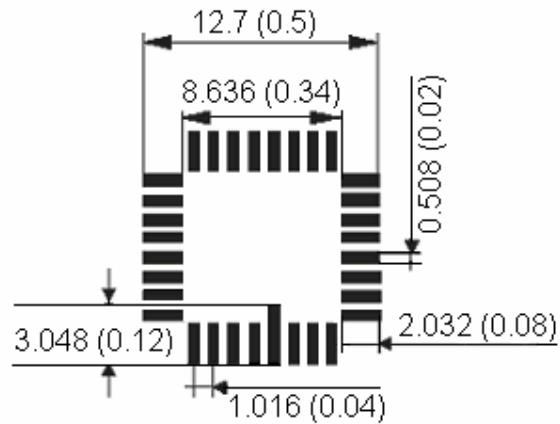

Figure 9-4. Land Pattern Design (top view)

## 10. Glossary of Terms

### Angular Rate Sensor

A sensor that measures rotational velocity measured in degrees per second around its sensitive axis. Angular rate sensors are sometimes referred to as gyro or gyroscope.

### Bandwidth

The input signal frequency range from DC (zero frequency) up to the frequency where a -3dB amplitude decay (between mechanical input and rate output) is observed. In the case of the present device, the bandwidth is user selectable by means of an external capacitor.

### Coriolis Effect

Coriolis Effect is an inertial force described by the 19th-century engineer-mathematician Gustave-Gaspard Coriolis in 1835. Coriolis showed that, if the ordinary Newtonian laws of motion of bodies are to be used in a rotating frame of reference, an inertial force, acting to the right of the direction of body motion for counterclockwise rotation of the reference frame or to the left for clockwise rotation, must be included in the motion equations.

In effect, the Coriolis force is an apparent deflection of the path of an object that moves within a rotating coordinate system. The object does not actually deviate from its path, but it appears to do so because of the motion of the coordinate system.

### Primary and Secondary Frame

In vector notation the Coriolis force  $F_{\text{Coriolis}}$  is given by:

$$\vec{F}_{\text{Coriolis}} = 2m(\vec{v} \times \vec{\Omega})$$

Where  $m$  is the mass of the object,  $\vec{v}$  its velocity and  $\vec{\Omega}$  is the angular rate of the rotating coordinate system.

To create a Coriolis Force ( $F_{\text{Coriolis}}$ ), a movement or velocity ( $\vec{v}$ ) must be induced. The gyroscope system has got an electrically actuated oscillating mechanical structure, called primary frame ( $m$ ).

When the gyroscope rotates ( $\vec{\Omega}$ ) a Coriolis force  $F_{\text{Coriolis}}$  acts on this frame. To measure the Coriolis force, a part of the frame - called the secondary frame - is designed to allow a motion as a reaction to the applied Coriolis force. This synchronous motion is sensed electrically by a capacitive readout circuit.

The gyroscope is a vibratory system with two orthogonal vibrating frames: the primary actuated vibrating frame and the secondary sensed vibrating frame.

### Zero Rate Output (ZRO) Drift

The bounds within which the circuit output signal may vary as the temperature varies across the operating temperature range with no applied angular rate.

### List of Acronyms

|             |   |
|-------------|---|
| ADC         | Analog to Digital Converter   |
| EEPROM      | Electrically Erasable PROM  |
| EMC         | Electro Magnetic Compatibility  |
| ESD         | Electrostatic Discharge   |
| HBM         | Human Body Model of ESD   |
| JEDEC       | Joint Electronics Design Engineering Council  |
| MEMS        | Micro Electro-Mechanical Sensor   |
| SMD         | Surface Mounted Device  |
| SO          | Swiss Outline or Small Outline  |
| SPI         | Serial Peripheral Interface   |
| TC          | Temperature Coefficient   |
| CDF-AEC-100 | Automotive Electronics Council –<br>Stress Test Qualification for Integrated Circuits |

## **11. Disclaimer**

Devices sold by Melexis are covered by the warranty and patent indemnification provisions appearing in its Term of Sale. Melexis makes no warranty, express, statutory, implied, or by description regarding the information set forth herein or regarding the freedom of the described devices from patent infringement. Melexis reserves the right to change specifications and prices at any time and without notice. Therefore, prior to designing this product into a system, it is necessary to check with Melexis for current information. This product is intended for use in normal commercial applications. Applications requiring extended temperature range, unusual environmental requirements, or high reliability applications, such as military, medical life-support or life-sustaining equipment are specifically not recommended without additional processing by Melexis for each application.

The information furnished by Melexis is believed to be correct and accurate. However, Melexis shall not be liable to recipient or any third party for any damages, including but not limited to personal injury, property damage, loss of profits, loss of use, interrupt of business or indirect, special incidental or consequential damages, of any kind, in connection with or arising out of the furnishing, performance or use of the technical data herein. No obligation or liability to recipient or any third party shall arise or flow out of Melexis' rendering of technical or other services.

© 2005 Melexis NV. All rights reserved.

For the latest version of this document, go to our website at  
**[www.melexis.com](http://www.melexis.com)**

Or for additional information contact Melexis Direct:

|  |  |
|--|--|
| <b>Europe, Africa, Asia:</b>   | <b>America:</b>  |
| Phone: +32 1367 0495   | Phone: +1 603 223 2362   |
| E-mail: <a href="mailto:sales_europe@melexis.com">sales_europe@melexis.com</a> | E-mail: <a href="mailto:sales_usa@melexis.com">sales_usa@melexis.com</a> |

ISO/TS 16949 and ISO14001 Certified