

# The MaxSonar-EZ1 High Performance Sonar Range Finder

The MaxSonar-EZ1 offers very short to long-range detection and ranging, in an incredibly small package with ultra low power consumption. The MaxSonar-EZ1 detects objects from 0-inches to 254-inches (6.45-meters) and provides sonar range information from 6-inches out to 254-inches with 1-inch resolution. Objects from 0-inches to 6-inches range as 6-inches. The interface output formats included are pulse width output, analog voltage output, and serial digital output.

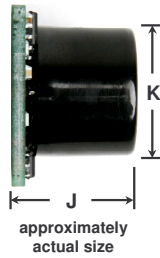

approximately actual size

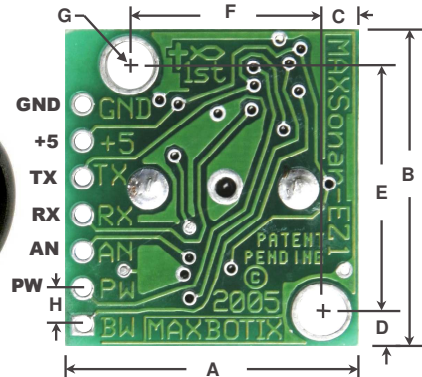

weight, 4.3 grams

A	0.785"	19.9 mm	F	0.510"	12.6 mm
B	0.870"	22.1 mm	G	0.124" dia.	3.1 mm dia.
C	0.100"	2.54 mm	H	0.100"	2.54 mm
D	0.100"	2.54 mm	J	0.645"	16.4 mm
E	0.670"	17.0 mm	K	0.610"	15.5 mm

dimensions are nominal

## Features

- Continuously variable gain for beam control and side lobe suppression
- Object detection includes zero range objects
- Single 5V supply with 2mA typical current draw
- Readings can occur up to every 50mS, (20-Hz rate)
- Free run operation can continually measure and output range information
- Triggered operation provides the range reading as desired
- All interfaces are active simultaneously
  - Serial, 0 to 5V
  - 9600Baud, 81N
  - Analog (10mV/inch)
  - Pulse width (147uS/inch)
- Learns ringdown pattern when commanded to start ranging
- Designed for protected indoor environments
- Sensor operates at 42KHz
- High output 10V PP square wave sensor drive

## Benefits

- Very low cost sonar ranger
- Half the size of other sensors in its class
- Sensor dead zone virtually gone
- No central blind spot
- Quality beam characteristics
- Mounting holes provided on the circuit board
- Lowest power ranger, excellent for multiple sensor or battery based systems
- Can be triggered externally or internally
- Sensor reports the range reading directly, frees up user processor
- Fast measurement cycle
- User can choose any of the three sensor outputs

## Beam Characteristics

Sample results for measured beam patterns are shown below on a 12-inch grid. The detection pattern is shown for;

- (A) 0.25-inch diameter dowel, note the very narrow beam for close small objects,
- (B) 1-inch diameter dowel, note the long narrow detection pattern,
- (C) 3.25-inch diameter rod, note the long controlled detection pattern,
- (D) 11-inch wide board moved left to right with the board parallel to the front sensor face and the sensor stationary. The displayed beam length shows the long-range capability of the sensor.

Note: The displayed beam width of (D) is a function of the specular nature of sonar and the shape of the board (i.e. flat mirror like) and should never be confused with actual sensor beam width.

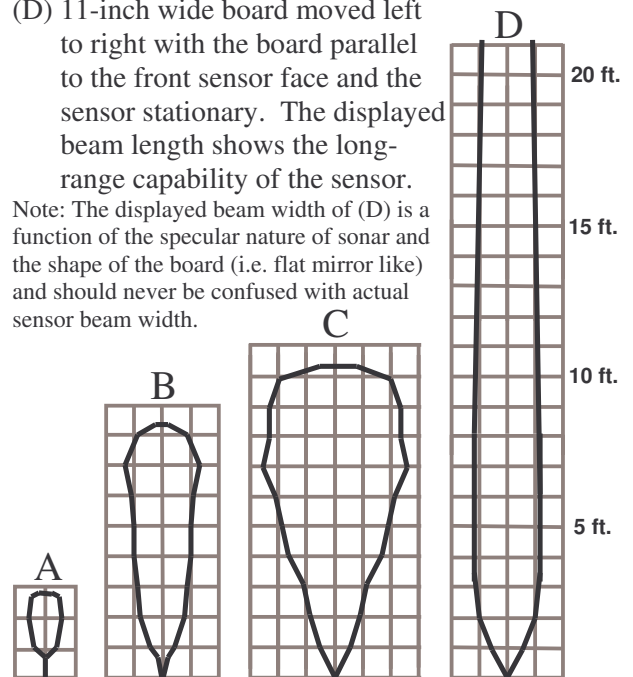

beam characteristics are approximate

# Maxbotix

EZ1 • v1.0 • 01/2006  
Copyright 2005 - 2006

8757 East Chimney Spring Drive, Tucson AZ, 85747 USA

Email: [info@maxbotix.com](mailto:info@maxbotix.com)

Web: [www.maxbotix.com](http://www.maxbotix.com)

### MaxSonar-EZ1 Pin Out

- GND** – Return for the DC power supply. Must be ripple and noise free for best operation.
- +5V** – Requires 5VDC +/- 0.5VDC. Current capability of 3mA capacity recommended.
- TX** – Delivers asynchronous serial with an RS232 format, except voltages are 0-5V. The output is an ASCII capital “R”, followed by three ASCII character digits representing the range in inches up to a maximum of 255, followed by a carriage return (ASCII 13). The baud rate is 9600, 8 bits, no parity, not inverted, with one stop bit. Although the voltage of 0-5 V is outside the RS232 standard, most RS232 devices have sufficient margin to read 0-5V serial data. If standard voltage level RS232 is desired, invert, and connect an RS232 converter such as a MAX232.
- RX** – This pin is internally pulled high. The EZ1 will continually measure range and output if RX data is left unconnected or held high. If held low the EZ1 will stop ranging. Bring high for 20uS or more to command a range reading.
- AN** – Outputs 0 to 2.55 volts with a scaling factor of 10mV per inch. The output is buffered and corresponds to the most recent range data.
- PW** – This pin outputs a pulse width representation of range. The distance can be calculated using the scale factor of 147uS per inch.
- BW** – N.C., Reserved

### MaxSonar-EZ1 Circuit

The MaxSonar-EZ1 circuit is formed with active components consisting of an LM324, a diode array, a PIC16F676, together with a variety of passive components.

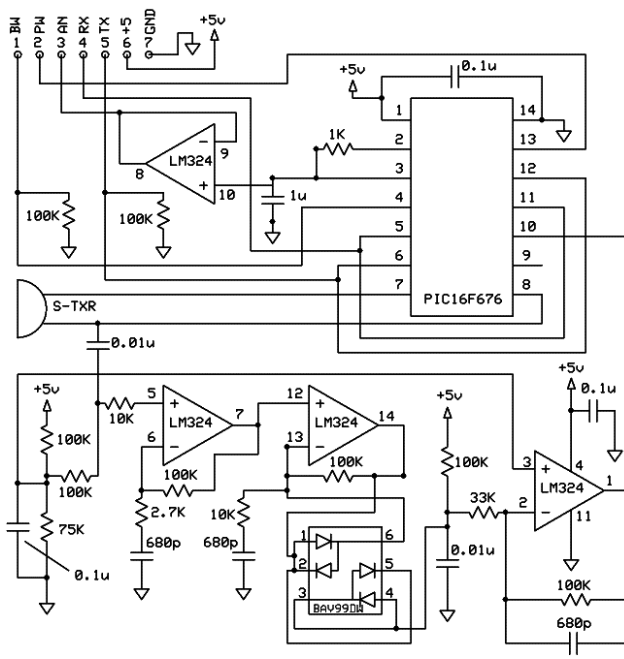

### MaxSonar-EZ1 Timing Description

250mS after power-up, the MaxSonar-EZ1 is ready to accept the RX command. If the RX pin is left open or held high, the sensor will first run a calibration cycle (49mS), and then it will take a range reading (49mS). Therefore, the first reading will take 100mS. Subsequent readings will take 49mS. The MaxSonar-EZ1 checks the RX pin at the end of every cycle. Range data can be acquired once every 49mS.

Each 49mS period starts by the RX being high or open, after which the MaxSonar-EZ1 sends seven 42KHz waves, after which the pulse width pin (PW) is set high. When a target is detected the PW pin is pulled low. The PW pin is high for up to 37.5mS if no target is detected. During the next 4.7mS the serial data is sent. The remainder of the 49mS time is spent adjusting the analog voltage to the correct level. When a long distance is measured immediately after a short distance reading, the analog voltage may not reach the exact level within one read cycle. The MaxSonar-EZ1 timing is factory calibrated to one percent and in use is better than two percent.

### MaxSonar-EZ1 General Power-Up Instruction

Each time after the MaxSonar-EZ1 is powered up, it will calibrate during its first read cycle. The sensor uses this stored information to range a close object. It is important that objects not be close to the sensor during this calibration reading. The best sensitivity is obtained when it is clear for fourteen inches, but good results are common when clear for at least seven inches. If an object is too close during the calibration cycle, the sensor may then ignore objects at that distance.

The MaxSonar-EZ1 does not use the calibration data to temperature compensate for range, but instead to compensate for the sensor ringdown pattern. If the temperature, humidity, or applied voltage changes during operation, the sensor may require recalibration to reacquire the ringdown pattern. If the temperature increases, the sensor is more likely to have false close readings. If the temperature decreases, the sensor is more likely to have reduced up close sensitivity. To recalibrate the MaxSonar-EZ1, cycle power, then command a read cycle.

Product / specifications subject to change without notice. Detailed user manual scheduled availability, April 2006.

# Maxbotix

EZ1 • v1.0 • 01/2006  
patent pending

8757 East Chimney Spring Drive, Tucson AZ, 85747 USA

Email: [info@maxbotix.com](mailto:info@maxbotix.com)

Web: [www.maxbotix.com](http://www.maxbotix.com)